

PHILIPS

Automatic digital multimeter

PM2523/..

9447 025 230,1

9499 470 13402

770915

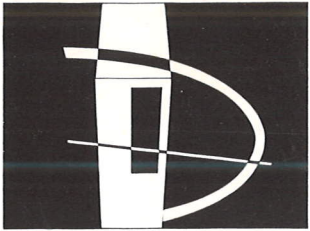

PHILIPS



Instruction manual

Automatic digital multimeter PM 2523/.

9447 025 230.1



9499 470 13402

770915

CONTENTS**GENERAL / ALLGEMEINES / GENERALITES**

1.	Introduction Einleitung Introduction	4 15 26
2.	Technical Data Technische Daten Caracteristiques Techniques	4 15 26
3.	Accessories Zubehör Accessoires	7 18 29
4.	Principle of operation Arbeitsweise Principe de fonctionnement	9 20 33

DIRECTION FOR USE / GEBRAUCHSANWEISUNG / MODE D'EMPLOI

5.	Installation Installation Mise en place	10 21 36
6.	Operation Bedienung Utilisation	12 23 40

SERVICE DATA

7.	Circuit description	45
8.	Access	62
9.	Trouble shooting	64
10.	Checking and Adjusting	71
11.	List of parts	74

IMPORTANT

In correspondence concerning this instrument please quote the type number and the serial number as given on the type plate at the rear of the instrument.

LIST OF FIGURES

1.	EHF probe type PM 9246 Hochspannungsmesskopf PM 9246 Sonde EHT PM 9246	30 30 30	23.	Pinning of the HEF 4739P	57
2.	Shunt PM 9244 Shunt PM 9244 Shunt PM 9244	30 30 30	24.	Block diagram HEF 4739P	57
3.	HF probe PM 9210 and accessory PM 9212 HF messkopf PM 9210 und zubehörsatz PM 9212 Sonde HF PM 9210 et accessoires PM 9212	30 30 30 30	25.	Fast acting filter	59
4.	Basic circuit of the ADC Prinzipschaltbild des ADU Circuit de base du CAD	34 34 34	26.	Power supply principle	60
5.	Block diagram Block schaltbild Schéma fonctionnel	34 34 34	27.	Rear view	63
6.	Adaption of the mains transformer and fuse Anpassung Netztransformator und Sicherung Adation du transformateur et fusible	38 38 38	28.	Removing and refitting top cover	63
7.	Rear view Rückansicht Vue arrière	38 38 38	29.	Power supply	66
8.	Front view Vorderansicht Vue avant	42 42 42	30.	Location jumpers A, B, C	66
9.	Location of fuse F1 Standort von Sicherung F1 Emplacement de fusible F1	42 42 42	31.	Reference	69
10.	Block diagram PM 2523	45	32.	Analogue to digital converter	69
11.	Block diagram analogue section	47	33.	x1 x10 amplifier	70
12.	Input circuit for d.c. voltage	47	34.	AC - DC converter	71
13.	Input filter	47	35.	Location of adjusting elements	72
14.	x1, x10 amplifier	49	36.	Front view with item numbers	75
15.	Protection circuit	49	37.	Rear view with item numbers	75
16.	Input for a.c. voltage	50	38.	P.c.b. U1 (component side)	81
17.	Buffer stage	49	39.	P.c.b. U1 (conductor side)	82
18.	AC - DC Converter	50	40.	P.c.b. U2 (component side)	81
19.	Input circuit for $K\Omega$ range	53	41.	P.c.b. U2 (conductor side)	82
20.	Principle resistance measurements	53	42.	Circuit diagram	85
21.	+ and – reference voltages	53			
22.	Block digital section	54			

1. INTRODUCTION

GENERAL

The PM 2523 is an accurate 3½ digit automatic V/Ω meter.

The instrument can be used for the following measurements:

- D.C. voltages of 100 μV to 1000 V
- A.C. voltages of 100 μV to 600 V_{rms}
- Resistances of 100 mΩ to 20 MΩ

Protection of all measurement functions is provided up to at least 250 V.

The polarity of d.c. voltages is indicated automatically.

LOC MOS technology allows the integration of most of the digital circuitry on a single chip, comprising A/D conversion, buffering and multiplexing of the result, and autoranging.

Data Hold, and Range Hold is possible by means of pushbutton switches.

In view of the ranges, automatic range selection, accuracy and rugged construction the instrument is an ideal general-purpose instrument for production lines, laboratories, servicing and education purposes.

2. TECHNICAL DATA

All values mentioned in this description are nominal; those given with tolerances are binding and guaranteed by the producer.

2.1. ELECTRICAL SPECIFICATIONS

Reference conditions

Temperature 23°C ± 2°C

Relative humidity < 70%

2.1.1. D.C. voltage measurements

Range

100 μV . . . 1000 V divided into 5 ranges

Range: 0.2 V

2 V

20 V

200 V

1000 V

Resolution

100 μV

Input resistance

10 MΩ in all ranges

Input capacitance

100 pF

Accuracy

± 0.1% of reading ± 0.1% of range in the ranges 0.2; 2; 20 and 200 V
± 0.2% of reading ± 0.2% of range in the 1000 V range

End of range value in the 1000 V range is 2000 V.

Temperature coefficient

± 200 ppm/°C

Maximum permissible voltage

1000 V

Series mode rejection

60 dB

Common mode rejection

100 dB

Max. common mode signal

500 V d.c. or 350 V a.c. 50 Hz

2.1.2. A.C. voltage measurements

Range	100 μ V ... 600 V _{rms} divided into 5 ranges		
	Ranges: 0.2 V		
	2 V		
	20 V		
	200 V		
	600 V		
Resolution	100 μ V _{rms}		
Input impedance	10 M Ω // 60 pF in all ranges		
Frequency range	30 Hz ... 30 KHz		
Accuracy	<u>Range</u>	<u>Frequency</u>	<u>Accuracy</u>
	0.2 V ... 200 V _{rms}	100 Hz ... 10 KHz	\pm 0.3% of reading \pm 0.3% of range
	0.2 V ... 200 V _{rms}	30 Hz ... 100 Hz	\pm 0.5% of reading
		10 KHz ... 30 KHz	\pm 0.5% of range
	600 V _{rms}	30 Hz ... 100 Hz	\pm 0.5% of reading \pm 0.5% of range
	End of range in the 600 V _{rms} range is 2000 V _{rms}		
Temperature coefficient	\pm 200 ppm/ $^{\circ}$ C		
Max. permissible voltage	600 V (100 Hz)		

2.1.3. Resistance measurements

Range	0.1 Ω ... 20 M Ω divided into 8 ranges		
	Ranges: 0.2 k Ω 0.2 M Ω		
	2 k Ω	2 M Ω	
	20 k Ω	20 M Ω	
	200 k Ω		
	2000 k Ω		
Resolution	0.1 Ω		
Measuring current	1 mA in the 0.2 k Ω and 2 k Ω ranges 10 μ A in the 20 k Ω ; 200 k Ω and 0.2 M Ω ranges 100 nA in the 200 k Ω ; 2 M Ω and 20 M Ω ranges		
Accuracy	\pm 0.2% of reading \pm 0.2% of range		
Temperature coefficient	250 ppm/ $^{\circ}$ C		
Maximum voltage with open input terminals	12 V		
Semiconductors	Can be measured in forward direction in the 2 k Ω range, in reverse direction in the higher ranges.		

2.2. GENERAL DATA

Environmental conditions	According to IEC 359
Climatic conditions	Group I with extension of the upper temperature limit to +50 $^{\circ}$ C Ambient temperature 23 $^{\circ}$ C \pm 2 $^{\circ}$ C Rated range of use 0 $^{\circ}$ C ... 45 $^{\circ}$ C Limit range of storage and transport -40 $^{\circ}$ C ... +70 $^{\circ}$ C Relative humidity 20% ... 80% (excluding condensation)

Mechanical conditions	Group II
Supply conditions	Group II Nominal mains supply 220 V +10% -12%
	<i>Note: Mains transformer wiring can be altered for a mains voltage of 110 V +10% -12%.</i>
	Mains frequency 48 - 65 Hz Battery supply by means of PM 9216. Power consumption approx. 12 VA
Safety class	Class I according to IEC 348
Conversion system	Delta pulse modulation system
Maximum display	1999
Number of digits	3½
Display control	Serial; scan frequency ≈ 500 Hz
Range switching time	0.5 sec./range
Conversion time	0.4 sec.
Response time	D.C. : 0.6 sec. with ranging max. 5 sec. A.C. : 0.6 sec. with ranging max. 5 sec. Ω : 0.9 sec. with ranging max. 8 sec.
Ranging	Down ranging at 0180 Up ranging at 1999
Representation of result and polarity	Seven segment "LED's"
Range selection	Automatic
Function selection	Manual by means of pushbuttons
Over-range indication	The indicator of the hundreds shows 0. the others are blanked
Decimal point	Set automatically by range selector
Measuring input	Floating
Capacitance between common and ground	1.8 nF
Zero point drift	± 150 ppm/°C
Maximum input voltages	Range V $\overline{=}$ 1000 V d.c. 600 V a.c. (50 Hz) V \sim 500 V d.c. 600 V a.c. (100 Hz) kΩ /MΩ 250 V d.c. or a.c.
	<i>Note: In the ranges 0.2 kΩ and 2 kΩ a fuse will blow if the input voltage exceeds 30 V d.c. or a.c.</i>
Dimensions	Height 95 mm Width 235 mm Depth 280 mm
Weight	approx. 2.0 kg

3. ACCESSORIES

3.1. SUPPLIED WITH THE INSTRUMENT

- 3 pole mains cable
- Set of measuring leads with test pins: PM 9260
- 1 fuse 80 mA slow blow (220 V mains supply)
- 2 fuses 160 mA slow blow (110 V mains supply)
- 1 fuse 125 mA slow blow (Ω ranges)
- 110 V Sticker
- Cover
- Manual.

3.2. OPTIONAL

3.2.1. EHT probe type PM 9246 (Fig. 1, page 30)

The EHT probe type PM 9246 is suitable for measuring direct voltages up to 30 kV. The PM 9246 may be used for measuring Instruments with an input impedance of 100 M Ω , 10 M Ω or 1.2 M Ω (selectable on the probe).

Maximum voltage	30 kV
Attenuation	1000 x
Input impedance	600 M Ω \pm 5%
Accuracy	\pm 3% for instrument impedance of 10 M Ω and 1000 M Ω
Relatively humidity	20% . . . 80%

3.2.2. Shunt type PM 9244 (Fig. 2, page 30)

With this shunt it is possible to measure d.c. and a.c. (max. 1 KHz) currents up to 31.6 A.

Current range	10 A and 31.6 A
Output voltage	100 mV and 31.6 mV
Accuracy	100 mV: \pm 1% 31.6 mV: \pm 2%
Dissipation	max. 3.16 W
Dimensions	Height 55 mm
	Width 140 mm
	Depth 65 mm

3.2.3. HF probe type PM 9210 (Fig. 3, page 30) Accessory set for HF probe type PM 9212

	<u>PM 9210</u>	<u>PM 9210 + PM 9212</u>
Frequency range	100 KHz ... 1 GHz	100 KHz ... 1 GHz
Straight line within 5%	100 KHz ... 6 MHz	100 KHz ... 6 MHz
Maximum deviation	3 dB	3,5 dB
Voltages ranges	150 mV ... 15 V	15 V ... 200 V

	<u>PM 9210</u>	<u>PM 9210 + PM 9212</u>
Max. voltage a.c.	30 V	200 V
Max. voltage d.c.	200 V	500 V
Input capacitance	2 pF	2 pF
T-piece	optional	
Frequency range		100 kHz . . . 1.2 GHz
Impedance		50 Ω
Standing wave ratio		1.25 at 700 MHz; with 1.15 at 1 GHz

Probe type PM 9210 in combination with the probe accessories (adjustable earthing pin and Dage adaptor) is suitable for measurements up to a frequency of 100 MHz.

For measurements beyond this frequency it is advisable to use the 50 Ω T-piece and the 50 Ω terminating resistance which are parts of the PM 9212 probe accessories set.

3.2.4. Battery supply unit type PM 9216

This battery supply unit may be attached to the rear of the instrument in order to provide battery operation. The batteries are charged by current obtained from the power supply circuits of the instrument.

Nominale voltage	5 V
Capacity	3.5 Ah
Maximum charge current	350 mA
Maximum trickle charge current	35 mA
Operation time provided by one charge in conjunction with the PM 2523	6 h
Recharge time	15 h

4. PRINCIPLE OF OPERATION (Fig.'s 4 and 5, page 34)

4.1. INPUT CIRCUIT

The purpose of the input circuit is to supply a direct voltage of 2 V to the ADC input, at end of range values. The analogue sections translate all input signals, i.e. d.c. and a.c. voltages and resistances to this signal of 2 V. For the d.c. and a.c. voltages the same divider is used. The attenuated signal is supplied to an 1x or 10x amplifier with an output of 2 V d.c. or 2 V_{rms}. In the case of a.c. voltage measurements the output of the amplifier is rectified by an a.c./d.c. convertor, which is switched off for d.c. voltage and resistance measurements. For resistance measurements a constant current passes through the unknown resistance according to the table below.

Ranges	Current	Measuring voltage (at end of range)
0.2 kΩ	1 mA	0.2 V
2 kΩ	1 mA	2 V
20 kΩ	10 μA	0.2 V
200 kΩ	10 μA	2 V
2000 kΩ	100 nA	0.2 V
0.2 MΩ	10 μA	2 V
2 MΩ	100 nA	0.2 V
20 MΩ	100 nA	2 V

The measuring voltage across the unknown resistance is supplied to the ADC via the 1x or 10x amplifier.

4.2. DIGITAL SECTION

The analogue to digital convertor of the PM 2523 is based on the principle of delta-pulse modulation. This integrating system ensures good linearity and series mode rejection. Furthermore the circuit contains a minimum of critical elements, as the accuracy of the reference voltage is only important for the accuracy of the ADC.

The basic principle of the analogue to digital convertor used in the PM 2523 is shown in figure 4, page 34.

FF is a flip-flop whose output operates a chopper switch which connects R either to a positive or negative reference voltage.

The state of the flip-flop depends on the level of the D input at the time of a sample pulse fs.

The level of the D input depends of the charge state of capacitor C.

Suppose that, at the instant of a pulse fs, the voltage level at D is below the working point of the flip-flop.

As a result, the chopper output becomes low and a negative reference voltage is connected via R to the integrator. The integrator output rises because $V_{ref} > V_i$ within the scale range. The output voltage is given by:

$$V_{Dc} = - \frac{1}{RC} (V_i - V_{ref}) t_c \quad (1)$$

(tc is the charging time)

At each succeeding sample pulse fs, V_D is sampled and when V_D exceeds the flip-flop working point, the flip-flop changes its state.

The integrator is then connected to +V_{ref}.

The integrator output now falls. The output voltage is given by:

$$V_{Dd} = - \frac{1}{RC} (V_i + V_{ref}) t_d \quad (2)$$

(td is the discharging time)

It will be seen that, providing that $V_i > 0$ the slope resulting from eq. (2) is greater than that resulting from eq. (1).

Since $V_{ref} > V_i$ is a condition, eqs. (1) and (2) show that the sign of the slope changes when the chopper is switched. Thus the output of the integrator is a saw tooth wave form which is drawn in figure 4 for a positive input. It can be further deduced from eqs (1) and (2) that for a negative input the slopes are reversed, i.e. the positive slope becomes the faster.

The digitized feedback limits the charge in the capacitor C so that a charge balance is obtained between the input voltage.

Due to this compensation method the average value of V_D ($V_{Dc} + V_{Dd}$) will be equal to V_i :

$$\text{This results in } V_i = \frac{t_c - t_d}{t_c + t_d} V_{ref} \quad (3)$$

$t_c + t_d = t_m$ (measuring time)

Let us assume N = total number of pulses fs during tm.

Then eq. (3) can be written as:

$$V_i = \frac{n - (N - n)}{N} V_{ref} = \frac{2n - N}{N} V_{ref} \quad (4)$$

Inasmuch an up/down counter is used to count up when $+V_{ref}$ is connected to the integrator and to count down when $-V_{ref}$ is connected to the integrator, after N sample times the contents of the counter will be $2n - N$.

In the HEF 4739 p used N = 4096 and $V_{ref} = 2.048$ V. To obtain a stable display the content is divided by two and transferred into a memory, after which the counter is reset. A new measurement can now start.

A multiplexer alternately connects each decade of the memory to the decoder driver. Simultaneously a pulse arises to drive the anode switch of the corresponding seven segments "LED". The decoded information will be transferred via the decoder driver to the indicator "LED's" mentioned whose cathodes are connected in parallel.

Only the indicator of which the anode switch is closed, will light up.

If that counted pulses exceed 2000, the range counter will come into its next position after which the next higher range is switched on and a new measuring cycle is automatically started.

Down ranging is effected at 0180 or less pulses, counted during one measuring cycle.

5. INSTALLATION

DIRECTIONS FOR USE

Before any other connection is made, the protective earth terminal shall be connected to a protective conductor (see section "EARTHING").

5.1. MAINS SUPPLY AND FUSE

Before inserting the mains plug into the mains socket, make sure that the instrument is set to the local mains voltage.

The instrument is wired for operation from a **220 V - 50 Hz** mains supply.

5.1.1. Adaption of mains voltage

By connecting the transformer windings as shown in figure 6, page 38 the instrument can be used with the following voltages:

220 V + 10% -12% . . . 50/60 Hz fuse: 80 mA slow blow
110 V + 10% -12% . . . 50/60 Hz fuse: 160 mA slow blow

Note: *When altering the mains transformer wiring for 110 V, the sticker supplied should be glued at the rear of the instrument.*

5.1.2. Fuses

The mains fuse is located on the printed circuit board at the lefthand side of the transformer (Fig. 6, page 38). To replace the mains fuse remove the top cover. (See section "ACCESS").

5.1.3. General

Adaption to the local mains voltage may be made only by a skilled person who is aware of the risks involved. When a fuse is to be replaced or when the instrument is to be adapted to another mains voltage, the instrument must be disconnected from all voltages sources.

5.2. BATTERY SUPPLY

The optional accessory PM 9216 is recommended for battery supply, because it becomes an integral part of the instrument.

5.2.1. Mounting the PM 9216

- Open the battery container cover of the multimeter.
- Connect the battery power supply plug to the battery socket of the multimeter.
- Place the PM 9216 in the battery container.
The two hooks of the PM 9216 should be placed in the corresponding two slots "A" (Fig. 7, page 38) of the battery container.
- Secure the PM 9216 by inserting the two screws supplied with the PM 9216 into the corresponding holes.

5.3. EARTHING

Before switching on, the instrument shall be connected to a protective earth conductor in one of the following way:

- via the three-core mains cable. The mains plug shall only be inserted into a socket outlet provided with a earth contact. The protective action shall not be made ineffective by the use of an extension cord without protective conductor. Replacing the mains plug is at the users own risk.

WARNING

Any interruption of the protective conductor inside the instrument or disconnection of the protective earth terminals is likely to make the instrument dangerous. Intentional interruption is prohibited. When an instrument is brought from the cold into a warm environment, condensation may cause a hazardous condition. Make sure therefore that the earthing requirements are strictly adhered to.

6. OPERATION

6.1. SWITCHING ON

The instrument is ready for use after connection to the mains and earthing. It is switched on by means of pushbutton switch "POWER" (Fig. 8, page 42).

6.2. CONTROLS

6.2.1. Front panel (Fig. 8, page 42)

Item	Description	Application
S101	POWER	Switches on the instrument.
S102	V $\overline{=}$; V \sim ; k Ω ; M Ω	Switches on the required measuring function.
S1	{ DATA HOLD RANGE HOLD	Display hold. Range hold.
X2	\perp	Earthing terminal
X3	0	Lo -input terminal
X4	V Ω	Combined Hi -input terminal of voltage and resistance measurements.
R1	"0"	Zero adjust.

6.2.2. Rear panel (Fig. 7, page 38)

Item	Description	Application
X1		Mains supply
X103		Battery supply

6.3. ZERO SETTING

Before carrying out the zero setting a warming-up time of 30 minutes should be allowed.

- Depress button V $\overline{=}$
- Short circuit V Ω and 0 terminals
- With R1 ("0") adjust the display to .0000 \pm 1 digit.

Note: For complete adjustments see chapter "Checking and adjusting".

6.4. MEASURING

6.4.1. Function selection

The measuring function required is set by the function selector.

V $\overline{=}$	100 μ V	...	1000 V d.c.
V \sim	100 μ V	...	600 V _{rms}
k Ω	0.1 Ω	...	2000 k Ω
M Ω	0.1 k Ω	...	20.00 M Ω

6.4.2. Direct voltage measurement

— Depress pushbutton V $\overline{=}$

— Connect the test voltage to terminals "0" and "V Ω "

Notes: — *The polarity indicator indicates the polarity at terminal "V Ω " with respect to terminal "0".*

— *Maximum permissible voltage between terminals "V Ω " and "0" is 1000 V d.c. or 600 V a.c. (50 Hz).*

6.4.3. EHT voltages up to 30 kV with probe type PM 9246

— Depress pushbutton V $\overline{=}$

— Connect the probe to terminals "0" and "V Ω " (terminals "0" and " \perp " should be interconnected).

— Connect the earthing clip of the probe to a proper earth.

— Select the 10 M Ω range on the probe.

Notes: — *Maximum permissible d.c. voltage 30 kV (range end is 100 kV).*

— *The position of the decimal point should be observed.*

6.4.4. Alternating voltage measurements

— Depress pushbutton V \sim

— Connect the test voltage to terminals "0" and "V Ω ".

Note: — *Maximum permissible voltage between terminals "V Ω " and "0" is 500 V d.c. or 600 V a.c. (100 Hz).*

6.4.5. UHF voltages with probe type PM 9210 and T-connector type PM 9212

— Depress pushbutton V \sim

— Connect the probe to terminals "0" and "V Ω " with the earthing pin to "0" (terminals "0" and " \perp " should be interconnected).

Notes: — *The maximum permissible voltage on the probe (with attenuator) is 200 V_{rms} superimposed on 500 V d.c.*

— *The correction factor on the calibration curve of the probe should be taken into account.*

6.4.6. Resistance measurements

— Depress pushbutton k Ω or M Ω

— Connect the unknown resistor to terminals "0" and "V Ω ".

Notes: — *The measuring current is:*
 1 mA for the 200 k Ω and 2 k Ω ranges
 10 μ A for the 20 k Ω and 200 k Ω ranges
 100 nA for the 2 M Ω and 20 M Ω ranges

6.4.7. Diodes

- Depress pushbutton $k\Omega$
- Connect the diode in forward direction to terminals "0" and " $V\Omega$ "
- Short circuit the diode until the lowest range is reached
- The display shows the diode voltage in forward direction of 1 mA Terminal " $V\Omega$ " is positive with respect to terminal "0".

6.5. GENERAL NOTES**6.5.1. Range hold**

When the "RANGE HOLD" pushbutton is depressed, the range, prior to depressing, is held and the position of the decimal point is fixed. Automatic ranging has been inhibited.

Example:

Input	Display	Range hold switch
0 V	.0000	–
+19.19 V	+19.19	–
+19.19 V	+19.19	Depressed
0 V	00.00	Depressed

6.5.2. Data hold

When the "DATA HOLD" pushbutton is depressed, the complete display, prior to depressing, is held.

6.5.3. Over-range indication

In the case of over-range, the LED indicator of the hundreds shows 0, the others are blanked.

Over-range is indicated when:

- The input signal exceeds the measurements range **held**.
- The $k\Omega$ or $M\Omega$ switch is depressed with the input terminals open, or when a resistor $> 20 M\Omega$ is connected.

1. EINLEITUNG

ALLGEMEINES

Das PM 2523 ist ein automatisches $V\Omega$ -Meter mit einer Anzeige von $3\frac{1}{2}$ Stellen und hoher Messgenauigkeit, das für folgende Messungen verwendet werden kann:

- Gleichspannungen von $100\ \mu\text{V}$ bis $1000\ \text{V}$
- Wechselspannungen von $100\ \mu\text{V}$ bis $600\ \text{V}_{\text{eff}}$
- Widerstände von $100\ \text{m}\Omega$ bis $20\ \text{M}\Omega$.

Das Gerät ist in allen Messbereichen bis mindestens $250\ \text{V}$ überlastungssicher. Die Polarität der Gleichspannungen wird automatisch angezeigt. Die meisten digitalen Schaltungen sind in LOC MOS-Technik auf einem einzigen Chip integriert: die A/D-Umsetzung, die Pufferung und die Steuerschaltung für die Anzeige sowie die automatische Bereichsumschaltung.

Anzeigespeicherung (Data Hold) und Bereichsspeicherung (Range Hold) ist mit Drucktasten einschaltbar.

Aufgrund der Messbereiche, der automatischen Bereichswahl, der Genauigkeit und der mechanischen Stabilität ist dieses Gerät ein ideales Vielzweckinstrument für sowohl die Produktion als auch für Laboren, den Service und für Unterrichtszwecke.

2. TECHNISCHE DATEN

Alle in dieser Beschreibung genannten Werte sind Nennwerte; Wert mit Toleranzangaben werden vom Hersteller garantiert.

2.1. ELEKTRISCHE SPEZIFIKATION

Umgebungsbedingungen $23^{\circ}\text{C} \pm 2^{\circ}\text{C}$
Relative Luftfeuchtigkeit $< 70\%$

2.2. Gleichspannungsmessungen

Bereich	$100\ \mu\text{V} \dots 1000\ \text{V}$ unterteilt in 5 Teilbereiche
Bereichen:	$0,2\ \text{V}$
	$2\ \text{V}$
	$20\ \text{V}$
	$200\ \text{V}$
	$1000\ \text{V}$

Auflösung $100\ \mu\text{V}$

Eingangswiderstand $10\ \text{M}\Omega$ in allen Bereichen

Eingangskapazität $100\ \text{pF}$

Fehlergrenze $\pm 0,1\%$ der Anzeige $\pm 0,1\%$ vom Bereichsendwert in den Bereichen $0,2; 2; 20$ und $200\ \text{V}$.
 $\pm 0,2\%$ der Anzeige $\pm 0,2\%$ vom Bereichsendwert im $1000\ \text{V}$ Bereich
Bereichsendwert im $1000\ \text{V}$ Bereich ist $2000\ \text{V}$.

Temperaturkoeffizient $\pm 200\ \text{ppm}/^{\circ}\text{C}$

Maximal zulässige Spannung $1000\ \text{V}$

Unterdrückung asymmetrischer
Störspannungen $60\ \text{dB}$

Unterdrückung symmetrischer Störspannungen (Gleichtakterdrückung) 100 dB

Maximales Gleichtaktsignal 500 V $\overline{\text{---}}$ oder 350 V \sim , 50 Hz

2.1.2. Wechselspannungsmessungen

Bereich 100 μV ... 600 V_{eff} unterteilt in 5 Teilbereiche
 Bereichen: 0,2 V
 2 V
 20 V
 200 V
 600 V

Auflösung 100 μV _{eff}

Eingangsimpedanz 10 M Ω //60 pF in alle Bereiche

Frequenzbereiche 30 Hz ... 30 kHz

<u>Bereich</u>	<u>Frequenz</u>	<u>Fehlergrenze</u>
0,2 V ... 200 V _{eff}	100 Hz ... 10 kHz	$\pm 0,3\%$ der Anzeige $\pm 0,3\%$ vom Bereichsendwert
0,2 V ... 200 V _{eff}	30 Hz ... 100 Hz	$\pm 0,5\%$ der Anzeige
600 V _{eff}	10 kHz ... 30 kHz	$\pm 0,5\%$ vom Bereichsendwert
	30 Hz ... 100 Hz	$\pm 0,5\%$ der Anzeige
		$\pm 0,5\%$ vom Bereichsendwert

Bereichsendwert im 600 V_{eff} Bereich ist 2000 V_{eff}.

Temperaturkoeffizient ± 200 ppm/ $^{\circ}\text{C}$

Maximal zulässige Spannung 600 V (100 Hz)

2.1.3. Widerstandsmessungen

Bereich 0,1 Ω ... 20 M Ω unterteilt in 8 Teilbereiche
 Bereichen: 0,2 k Ω 0,2 M Ω
 2 k Ω 2 M Ω
 20 k Ω 20 M Ω
 200 k Ω
 2000 k Ω

Auflösung 0,1 Ω

Messstrom 1 mA in den Bereichen 0,2 k Ω und 2 k Ω
 10 μA in den Bereichen 20 k Ω , 2 M Ω und 20 M Ω
 100 nA in den Bereichen 200 k Ω , 2 M Ω und 20 M Ω

Fehlergrenze $\pm 0,2\%$ der Anzeige
 $\pm 0,2\%$ vom Bereichsendwert

Temperaturkoeffizient 250 ppm/ $^{\circ}\text{C}$

Maximale Spannung an den Messklemmen 12 V

Halbleiter

Können in Durchlassrichtung im 2 k Ω -Bereich gemessen werden, in Sperrichtung in einem höheren Bereich.

2.2. ALLGEMEINE ANGABEN

Umgebungsbedingungen

Nach IEC 359

Klimatische Bedingungen	Gruppe I mit Erweiterung der oberen Temperaturgrenze von $\pm 50^{\circ}\text{C}$ Umgebungstemperatur $23^{\circ}\text{C} \pm 2^{\circ}\text{C}$ Betriebstemperaturbereich $0^{\circ}\text{C} \dots 45^{\circ}\text{C}$ Temperaturbereich für Lagerung und Transport $-40^{\circ}\text{C} \dots +70^{\circ}\text{C}$ Relative Luftfeuchtigkeit 20% ... 80% (mit Ausnahme von Kondensation)
Mechanische Bedingungen	Gruppe II
Stromversorgung	Gruppe II Nominale Netzspannung 220 V +10% und -12% <u>Anmerkung:</u> Der Netztransformator kann intern auf 110 V +10 und -12% umgeschaltet werden. Netzfrequenz 48 - 65 Hz Batteriebetrieb möglich mit PM 9216 Leistungsaufnahme ca. 12 VA
Schutzklasse	Klasse I nach IEC 348
Umsetzung	Delta- Impuls- Modulation
Maximale Anzeige	1999
Anzahl der Stellen	3½
Abtaststeuerung	Laufend, Abtastfrequenz ≈ 500 Hz
Bereichswahlzeit	0,5 sek. pro Bereich
Umsetzzeit	0,4 sek.
Ansprechzeit	In dem Gleich- und Wechselspannungsbereichen: max. 0,6 sek. mit Bereichsumschaltung: max. 5 sek. In den Widerstandsbereichen: max. 0,9 sek. mit Bereichsumschaltung: max. 8 sek.
Bereichswahl	Nach oben bei 0180 Nach unten bei 1999
Anzeige des Ergebnisses und der Polarität	Sieben-Segment-LED's
Bereichswahl	Automatisch
Wahl der Betriebsart	Von Hand mit Tasten
Überbereichsanzeige	In der Hundertler-Position erscheint eine 0, in den übrigen Feldern nichts
Dezimalstellen-Anzeige	Wird automatisch mit Bereichsschalter umgeschaltet
Messeingang	Schwebend
Kapazität zwischen der Schaltungserde und Masse	1,8 nF
Nullpunktdrift	± 150 ppm/ $^{\circ}\text{C}$
Maximale Eingangsspannungen	Bereich: V $\overline{=}$ 1000 V $\overline{=}$ 600 V \sim (50 Hz) V \sim 500 V $\overline{=}$ 600 V \sim (100 Hz) k Ω /M Ω 250 V $\overline{=}$ oder \sim
	<u>Anmerkung:</u> In den Bereichen 0,2 k Ω und 2 k Ω schmilzt eine Sicherung, wenn die Eingangsspannung 30 V $\overline{=}$ oder \sim überschreitet.
Anmessungen	Höhe 95 mm Breite 235 mm Tiefe 280 mm
Gewicht	ca. 2,0 kg

3. ZUBEHÖR

3.1. MIT DEM GERÄT MITGELIEFERTES ZUBEHÖR

- Drei-adriges Netzkabel
- Satz Messkabel mit Prüfspitzen PM 9260
- 1 Sicherung 80 mA, träge (für Netzspannung 220 V)
- 2 Sicherungen 160 mA, träge (für Netzspannung 110 V)
- 1 Sicherung 125 mA (für Widerstandsmessungen)
- Aufkleber 110 V
- Schutzhaube
- Bedienungsanleitung

3.2. WAHLZUBEHÖR

3.2.1. Hochspannungs-Messkopf PM 9246 (Abb. 1, Seite 30)

Mit dem Hochspannungs-Messkopf PM 9246 können Gleichspannungen bis 30 kV gemessen werden. Der Messkopf PM 9246 ist für Messgeräte mit einer Eingangsimpedanz von 100 M Ω , 10 M Ω oder 1,2 M Ω geeignet (auf dem Messkopf wählbar).

Maximale Spannung	30 kV
Abschwächung	1000 x
Eingangsimpedanz	600 M Ω \pm 5%
Fehlergrenze	\pm 3% bei Geräten mit einer Eingangsimpedanz von 10 M Ω oder 100 M Ω
Relative Luftfeuchtigkeit	20% ... 80%

3.2.2. Shunt PM 9244 (Abb. 2, Seite 30)

Mit Hilfe dieses Parallelwiderstandes können Gleich- und Wechselströme (max. 1 kHz) bis 31,6 A gemessen werden.

Strombereich	10 A und 31,6 A
Ausgangsspannung	100 mV und 31,6 mV
Fehlergrenze	100 mV: \pm 1% 31,6 mV: \pm 2%
Verlustleistung	max. 3,16 W
Abmessungen	Höhe 55 mm
	Breite 140 mm
	Tiefe 65 mm

3.2.3. HF-Messkopf PM 9210 Zubehörsatz für HF-Messkopf PM 9212 (Abb. 3, Seite 30)

	<u>PM 9210</u>	<u>PM 9210 + PM 9212</u>
Frequenzbereich	100 kHz ... 1 GHz	100 kHz ... 1 GHz
Kennliniengerade innerhalb 5%	100 kHz ... 6 MHz	100 kHz ... 6 MHz
Maximale Abweichung	3 dB	3,5 dB
Spannungsbereichen	150 mV ... 15 V	15 V ... 200 V

	<u>PM 9210</u>	<u>PM 9210 + PM 9212</u>
Maximale Eingangswechselspannung	30 V	200 V
Maximale Eingangsgleichspannung	200 V	500 V
Eingangskapazität	2 pF	2 pF
T-Stück	Wahlzubehör	
Frequenzbereich		100 kHz ... 1,2 GHz
Impedanz		50 Ω
Stehwellenverhältnis		1,25 bei 700 MHz; mit 1,15 bei 1 GHz

Zusammen mit dem Messkopf-Zubehör (einstellbarer Erdungsstift und Dage-Adaptor) können mit dem Messkopf PM 9210 Spannungen mit Frequenzen bis 100 MHz gemessen werden. Für höhere Frequenzen wird die Verwendung des 50- Ω -T-Stücks und des 50- Ω -Abschlusswiderstandes empfohlen, die zu dem Messkopf-Zubehörsatz PM 9212 gehören.

3.2.4. Batterie-Einheit PM 9216

Wird diese Batterie-Einheit an der Rückseite des Geräts angebracht, ist Batteriebetrieb möglich. Die Batterie wird mit Strom aus dem Netzteil des Gerätes geladen.

Netzspannung	5 V
Kapazität	3,5 Ah
Maximaler Ladestrom	350 mA
Maximaler Pufferstrom	35 mA
Betriebszeit des PM 2523 mit vollgeladener Batterie	6 h
Ladezeit	15 h

4. ARBEITSWEISE (Abb. 4 und 5, Seite 34)

4.1. EINGANGSSCHALTUNG

Die Eingangsschaltung hat die Aufgabe, in allen Bereichen eine solche Spannung zu erzeugen, dass der Analog-Digital-Umsetzer (ADC) am Bereichsende eine Spannung von 2 V erhält. In den analogen Stufen werden alle Eingangssignale - Gleichspannungen, Wechselspannungen und Widerstände in dieses Signal von 2 V umgewandelt.

Für die Gleich- und Wechselspannungen wird derselbe Spannungsteiler verwendet.

Das abgeschwächte Signal wird in einem Verstärker einmal oder zehnmal verstärkt, so dass man eine Gleich oder Wechselspannung von 2 V am Bereichsende erhält.

Bei Wechselspannungsmessungen wird die Ausgangsspannung des Verstärkers von einem Gleichrichter gleichgerichtet, der bei Gleichspannungs- und Widerstandsmessungen nicht eingeschaltet ist.

Bei Widerstandsmessungen fließt durch den unbekanntem Widerstand ein konstanter Strom, dessen Wert der folgenden Tabelle entnommen werden kann.

Bereich	Strom	Messspannung (am Bereichsende)
0,2 kΩ	1 mA	0,2 V
2 kΩ	1 mA	2 V
20 kΩ	10 μA	0,2 V
200 kΩ	10 μA	2 V
2000 kΩ	100 nA	0,2 V
0,2 MΩ	10 μA	2 V
2 MΩ	100 nA	0,2 V

Die an den unbekanntem Widerstand gemessene Spannung gelangt über den 1x- oder 10x-Verstärker an den ADC.

4.2. DIGITALER TEIL

Der Analog-Digital-Umsetzer des PM 2523 arbeitet nach dem Prinzip der Delta-Impuls-Modulation. Dieses Integrationssystem zeichnet sich durch eine gute Linearität und Unterdrückung von asymmetrischen Störspannungen aus. Ausserdem enthält diese Schaltung nur wenige kritische Bauelemente: die Genauigkeit des ADC hängt deshalb nur von der Genauigkeit der Referenzspannung ab.

Das Prinzip des im PM 2523 benutzten Analog-Digital-Umsetzers ist in Abb. 4, auf Seite 34 dargestellt.

FF ist ein Flip-Flop, dessen Ausgangssignal eine Schalter so steuert, dass er entweder mit einer positiven oder einer negativen Referenzspannung verbunden wird.

Der Zustand des Flip-Flops hängt davon ab, welcher Pegel Eingang D zum Zeitpunkt des Abtastimpulses f_s hat.

Der Pegel von Eingang D hängt wiederum von der Ladung von Kondensator C ab.

Angenommen, dass der Spannungspegel bei D im Augenblick von Impulse f_s unterhalb des Ansprechpunktes des Flip-Flops ist. Dann wird der Ausgang des Schalters niedrig und die negative Referenzspannung kommt über R an den Integrator.

Die Ausgangsspannung des Integrators wird grösser, weil innerhalb des Skalenbereichs $V_{ref} > V_i$.

Die Ausgangsspannung ist gegeben durch:

$$V_{Dc} = - \frac{1}{RC} (V_i - V_{ref}) t_c \quad (1)$$

(t_c ist die Ladezeit)

Bei jedem folgenden Abtastimpuls f_s wird V_D abgestastet; wenn V_D dann den Ansprechpunkt des Flip-Flops überschreitet, ändert das Flip-Flop seinen Zustand.

Der Integrator wird dann mit $+V_{ref}$ verbunden.

Nun sinkt die Ausgangsspannung des Integrators. Die Ausgangsspannung ergibt sich nach folgender Formel:

$$V_{Dd} = - \frac{1}{RC} (V_i + V_{ref}) t_d \quad (2)$$

(t_d ist die Entladezeit).

Es ist zu sehen, dass unter der Voraussetzung, dass $V_i > 0$ ist, der sich anhand von Gleichung (2) ergebende Abfall grösser als der ist, der sich aus Gleichung (1) ergibt.

Da die Bedienung $V_{ref} > V_i$ gegeben ist, lassen die Gleichungen (1) und (2) erkennen, dass das Vorzeichen für die Flanke sich ändert, wenn der Schalter umgeschaltet wird. Dementsprechend hat die Ausgangsspannung des Integrators eine Sägezahnform, wie sie in Abb. 4 für eine positive Eingangsspannung dargestellt ist.

Ferner kann aus den Gleichungen (1) und (2) abgeleitet werden, dass bei einem negativen Eingangssignal die Flanken umgekehrt verlaufen, d.h., die positive Flanke wird steiler.

Die digitale Gegenkopplung begrenzt die Ladung von Kondensator C so, dass sich zwischen der Eingangsspannung und der Referenzspannung ein Ladungsgleichgewicht einstellt.

Durch diese Kompensationsmethode wird der Mittelwert von $V_D(V_{Dd} + V_{Dd})$ gleich V_i .

$$\text{Das ergibt } V_i = \frac{tc - td}{tc + td} V_{ref} \quad (3)$$

$$tc + td = tm \quad (\text{Messzeit})$$

Angenommen N = gesamte Anzahl der Impulse f_s während tm

n = gesamte Anzahl der Impulse f_s während tc.

Nun kann Gleichung (3) wie folgt geschrieben werden:

$$V_i = \frac{n - (N - n)}{N} \cdot V_{ref} = \frac{2n - N}{N} V_{ref} \quad (4)$$

Da ein Vor Rückzähler verwendet wird, der aufwärts zählt, wenn $+V_{ref}$ mit dem Integrator verbunden ist, und abwärts, wenn $-V_{ref}$ mit dem Integrator verbunden ist, beträgt der Zählerinhalt nach N Abtastungen $2n - N$. In dem HEF 4739P ist $N = 4096$ und $V_{ref} = 2,048$ V. Um eine stabile Anzeige zu erhalten, wird der Inhalt durch zwei geteilt und in einen Speicher übertragen, wonach der Zähler zurückgesetzt wird. Eine neue Messung kann nun beginnen.

Ein Multiplexer verbindet abwechselnd jede Dekade des Speichers mit der Dekoder-Treiberstufe. Gleichzeitig entsteht ein Impuls, der den Anodenschalter der zugehörigen Sieben-Segment-LED steuert. Über die Dekoder-Treiberstufe wird die dekodierte Information in die bereits genannten Anzeige-LEDs übertragen, deren Katoden parallel geschaltet sind.

Es leuchtet aber nur derjenige Indikator, dessen Anodenschalter geschlossen ist.

Sobald mehr als 2000 Impulse gezählt sind, kommt der Bereichszähler in seine Stellung, wodurch der nächsthöhere Bereich eingeschaltet und automatisch ein neuer Messzyklus gestartet wird.

In einen niedrigen Bereich wird eingeschaltet, wenn während eines Messzyklus 180 oder weniger Impulse gezählt werden.

5. INSTALLATION

GEBRAUCHSANWEISUNG

Vor der Inbetriebnahme ist immer für eine geeignete Erdung des Gerätes zu sorgen (siehe den Abschnitt "ERDUNG").

5.1. NETZANSCHLUSS UND SICHERUNG

Bevor der Netzstecker in die Steckdose gesteckt wird, ist zu kontrollieren, ob das Gerät für die vorhandene Spannung geeignet ist.

Das Gerät wird für den Anschluss an eine Netzspannung von **220 V und 50 Hz** geliefert.

5.1.1. Anpassung an die Netzspannung

Durch Umschalten der Transformatorwicklungen, wie es in Abb. 6, Seite 38 gezeigt is, kann das Gerät für folgende Netzspannungen eingestellt werden:

220 V	+10%	-12%,	50/60 Hz	Sicherung:	80 mA träge
110 V	+10%	-12%,	50/60 Hz	Sicherung:	160 mA träge

Anmerkung: Wird das Gerät für eine Netzspannung von 110 V umgeschaltet, ist der mitgelieferte Aufkleber auf die Rückseite des Geräts zu kleben.

5.1.2. Sicherung

Die Netzsicherung befindet sich auf der Leiterplatte links neben dem Transformator (Abb. 6, Seite 38). Für den Ersatz der Netzsicherung muss das Gerät geöffnet werden (siehe den Abschnitt "ACCESS").

5.1.3. General

Die Netzspannung darf im Gerät nur von einem Fachmann umgeschaltet werden. Wenn eine Sicherung ersetzt oder die Netzspannung umgeschaltet werden soll, muss das Gerät unbedingt von allen Spannungsquellen getrennt werden.

5.2. BATTERIEBETRIEB

Für Batteriebetrieb wird das Zubehör PM 9216 empfohlen, das dann zu einem Bestandteil des Gerätes wird.

5.2.1. Einbau des PM 9216

Den Deckel des Batteriefachs des Multimeters öffnen.
Den Stecker des Batteriespannungskabels an die Batteriespannungsbuchse des Geräts anschliessen.
Die Einheit PM 9216 in das Batteriefach einsetzen.
Die beiden Haken des PM 9216 müssen in die beiden entsprechenden Schlitze A (Abb. 7, Seite 38) des Batteriefachs kommen. Die Einheit PM 9216 mit den beiden mitgelieferten Schrauben in den entsprechenden Löchern festsetzen.

5.3. ERDUNG

Vor dem Einschalten muss das Gerät nach der folgenden Methoden geerdet werden:

— über das dreiradrigge Netzkabel; der Netzstecker muss dann in eine Schuko-Steckdose gesteckt werden. Die Erdleitung darf dann aber nicht durch ein Verlängerungskabel ohne Erdleitung unterbrochen werden. Wird ein anderer Netzstecker montiert, muss der Benutzer sich der damit verbundenen Gefahren bewusst sein.

WARNUNG

Bei einer Unterbrechung des Schutzleiters im oder ausserhalb des Geräts, und wenn das Gerät dann nicht an der Erdungsbuchse geerdet ist, kann das Gerät für den Bedienenden eine Gefahrenquelle darstellen. Eine vorsätzliche Unterbrechung der Erdleitung ist nicht gestattet. Wird das Gerät von einer kalten Umgebung in einen warmen Raum gebracht, kann auch die Kondensationsfeuchtigkeit zu gefährlichen Betriebsbedingungen führen. Auch deshalb ist darauf zu achten, dass das Gerät immer einwandfrei geerdet wird.

6. BEDIENUNG

6.1. EINSCHALTEN

Das Gerät ist sofort betriebsbereit, wenn es an das Netz angeschlossen und geerdet ist. Es lässt sich dann mit der Taste "POWER" einschalten (Abb. 8, Seite 42).

6.2. BEDIENUNGSORGANE

6.2.1. Vorderseite (Abb. 8, Seite 42)

Position	Beschreibung	Anwendung
S101	POWER	Einschalten des Geräts
S102	V Ω ; V \sim ; k Ω ; M Ω	Einschalten der gewünschten Betriebsart
S1	{ DATA HOLD RANGE HOLD	Anzeigespeicherung Bereichsspeicherung
X2	\perp	Erdanschluss
X3	0	Gemeinsamer Anschluss
X4	V Ω	Anschluss für Spannungs- und Widerstandsmessungen
R1	"0"	Nullpunkteinstellung

6.2.2. Rückseite (Abb. 7, Seite 38)

Position	Beschreibung	Anwendung
X1		Netzanschluss
X103		Batterieanschluss

6.3. NULLPUNKTEINSTELLUNG

Der Nullpunkt sollte erst nach einer Anlaufzeit des Geräts von 30 Minuten eingestellt werden.

- Taste V Ω drücken
- Die Anschlüsse V Ω und 0 kurzschliessen
- Mit R1 ("0") die Anzeige auf .0000 \pm einen Zifferwert einstellen.

Anmerkung: Für den vollständigen Abgleich des Geräts siehe das Kapitel "Checking and adjusting".

6.4. MESSUNG

6.4.1. Wahl der Betriebsart

Die gewünschte Betriebsart kann mit einem Schalter eingestellt werden.

V $\overline{=}$	100 μ V	...	1000 V
V \sim	100 μ V	...	600 V _{eff}
k Ω	0,1 Ω	...	2000 k Ω
M Ω	0,1 k Ω	...	20,00 M Ω

6.4.2. Gleichspannungsmessungen

– Taste V $\overline{=}$ drücken

– Die zu messende Spannung an die Buchsen "0" und "V Ω " anschliessen.

Anmerkungen: – Der Polaritätsanzeiger zeigt die Polarität an Anschluss "V Ω " gegenüber Anschluss "0" an.

– Die Spannung zwischen den Anschlüssen "V Ω " und "0" darf max. 1000 V $\overline{=}$ oder 600 V \sim (50 Hz) betragen.

6.4.3. Hochspannungen bis 30 kV mit Messkopf PM 9246

– Taste V $\overline{=}$ drücken

– Den Messkopf an die Anschlüsse "0" und "V Ω " anschliessen. (die Anschlüsse "0" und "⊥" müssen miteinander verbunden sein)

– Den Erdungsklip des Messkopfes einwandfrei erden

– Den Messkopf auf 10 M Ω umschalten.

Anmerkungen: – Es dürfen nur Gleichspannungen bis max. 30 kV angeschlossen werden (Bereichsende ist 100 kV).

– Die Dezimalstelle ist zu beachten.

6.4.4. Wechselspannungsmessungen

– Taste V \sim drücken

– Die zu messende Spannung an die Anschlüsse "0" und "V Ω " anschliessen.

Anmerkung: – Die Spannung zwischen den Anschlüssen "V Ω " und "0" darf max. 500 V $\overline{=}$ oder V \sim (100 Hz) betragen.

6.4.5. UHF-Spannungen mit Messkopf PM 9210 und T-Stück PM 9212

– Taste V \sim drücken

– Den unbekanntem Widerstand an "0" und "V Ω " anschliessen. Erdungsstift an "0" (die Anschlüsse "0" und "⊥" sind miteinander zu verbinden).

Anmerkungen: – An den Messkopf (mit Abschwächer) darf eine Wechselspannung von max. 200 V_{eff} angeschlossen werden, die einer Gleichspannung von 500 V überlagert sein darf.

– Der Korrekturfaktor auf der Kalibrierkurve des Kopfes ist zu beachten.

6.4.6. Widerstandsmessungen

– Taste k Ω oder M Ω drücken

– Den unbekanntem Widerstand an "0" und "V Ω " anschliessen.

Anmerkungen: – Der Messstrom beträgt:

1 mA in den Bereichen 200 Ω und 2 k Ω

10 nA in den Bereichen 20 k Ω und 200 k Ω

100 nA in den Bereichen 2 M Ω und 20 M Ω

6.4.7. Dioden

- Tasten $k\Omega$ drücken
- Die Diode in Durchlassrichtung an "0" und " $V\Omega$ " anschliessen
- Die Diode kurzschliessen, bis der kleinste Bereich erreicht ist.
- Es wird die Spannung an der Diode Durchlassrichtung bei einem Strom von 1 mA angezeigt. Anschluss " $V\Omega$ " is positiv gegenüber Anschluss "0".

6.5. ALLGEMEINE HINWEISE**6.5.1. Bereichspeicherung**

Wird die Taste "RANGE HOLD" gedrückt, bleibt der gerade eingeschaltete Bereich eingestellt und die Dezimalstellenanzeige ändert sich nicht. Die automatische Bereichsumschaltung ist dann ausser Betrieb.

Beispiel:

Eingangsspannung	Anzeige	Schalter RANGE HOLD
0 V	.0000	–
+ 19.19 V	+ 19.19	–
+ 19.19 V	+ 19.19	gedrückt
0 V	00.00	gedrückt

6.5.2. Anzeigespeicherung

Wird die Taste "DATA HOLD" gedrückt, bleibt der gerade angezeigte Wert stehen.

6.5.3. Überbereichsanzeige

Bei Überschreitung des Messbereichs wird in der Hunderter-Position eine 0 angezeigt, in den anderen Feldern nichts. Eine Bereichsüberschreitung wird angezeigt, wenn:

- das Eingangssignal grösser als der eingestellte Messbereich ist,
- Schalter $k\Omega$ oder $M\Omega$ gedrückt ist, aber kein Widerstand oder ein Widerstand $> 20 M\Omega$ angeschlossen ist.

1. INTRODUCTION

GENERALITES

Le PM 2523 est un voltmètre-ohmmètre automatique et précis, à 3½ digits.

Il peut servir aux mesures suivantes:

- tensions continues de 100 μ V à 1000 V
- tensions alternatives de 100 μ V à 600 V_{eff}
- résistances de 100 m Ω à 20 M Ω

La protection de toutes les fonctions de mesure est assurée jusqu'au moins 250 V.

La polarité de tension continue est indiquée automatiquement.

La technologie LOC MOS permet l'intégration de la plupart des circuits digitaux sur un chip unique, entre autres les circuits de conversion analogique/numérique, la stockage intermédiaire et le multiplexage du résultat, ainsi que le changement automatique de gamme.

La maintien de l'information et celui de la gamme sont possibles par boutons-poussoirs.

Compte tenu de ces gammes, de la sélection automatique de gamme, de sa précision et de sa robustesse, le PM 2523 constitue un instrument universel idéal pour les chaînes de fabrication, les laboratoires, l'entretien et l'enseignement.

2. CARACTERISTIQUES TECHNIQUES

Toutes les valeurs mentionnées sont nominales; celles qui comportent des tolérances engagent le fabricant et sont garanties par lui.

2.1. CARACTERISTIQUES ELECTRIQUES

Condition de référence température 23°C \pm 2°C
 humidité relative \leq 70%

2.1.1., Mesure de tensions continues

Gamme 100 μ V . . . 1000 V, divisée en 5 gammes

 Gamme: 0,2 V

 2 V
 20 V
 200 V
 1000 V

Résolution 100 μ V

Résistance d'entrée 10 M Ω dans toutes les gammes

Capacité d'entrée 100 pF

Précision \pm 0,1% de la mesure \pm 0,1% de la gamme dans les gammes 0,2; 2; 20
 et 200 V
 \pm 0,2% de la mesure \pm 0,2% de la gamme dans la gamme 1000 V
 Fin de gamme dans la gamme 1000 V est 2000 V.

Coefficient de température \pm 200 ppm/°C

Tension maximale admissible 1000 V

Réjection mode série 60 dB

Réjection mode commun 100 dB

Signal maximum mode commun 500 V continue ou 350 V alternatif, 50 Hz

2.1.2. Mesure de tensions alternative

Gamme	100 μ V ... 600 V _{eff} , divisée en 5 gammes		
Gammes:	0,2 V		
	2 V		
	20 V		
	200 V		
	600 V		
Résolution	100 μ V _{eff}		
Impédance d'entrée	10 M Ω //60 pF dans toutes les gammes		
Gamme de fréquence	30 Hz ... 30 KHz		
Précision	<u>Gamme</u>	<u>Fréquence</u>	<u>Précision</u>
	0,2 V ... 200 V _{eff}	100 Hz ... 10 KHz	$\pm 0,3\%$ de la mesure $\pm 0,3\%$ de la gamme
	0,2 V ... 200 V _{eff}	30 Hz ... 100 Hz	$\pm 0,5\%$ de la mesure
	600 V _{eff}	10 KHz ... 30 KHz	$\pm 0,5\%$ de la gamme
	600 V _{eff}	30 Hz ... 100 Hz	$\pm 0,5\%$ de la mesure $\pm 0,5\%$ de la gamme
	Fin de gamme dans la gamme 600 V _{eff} ets 2000 V _{rms} .		
Coefficient de température	± 200 ppm/ $^{\circ}$ C		
Tension maximale admissible	600 V (100 Hz)		

2.1.3. Mesure de résistances

Gamme	0,1 Ω ... 20 M Ω , divisée en 8 gammes		
Gammes:	0,2 k Ω	0,2 M Ω	
	2 k Ω	2 M Ω	
	20 k Ω	20 M Ω	
	200 k Ω		
	2000 k Ω		
Résolution	0,1 Ω		
Courant de mesure	1 mA dans les gammes 0,2 k Ω et 0,2 M Ω 10 μ A dans les gammes 20 k Ω , 200 k Ω et 0,2 M Ω 100 nA dans les gammes 200 k Ω , 2 M Ω et 20 M Ω		
Précision	$\pm 0,2\%$ de la mesure $\pm 0,2\%$ de la gamme		
Coefficient de température	250 ppm/ $^{\circ}$ C		
Tension maxi avec des bornes d'entrée ouverte	100 pF		
Semiconducteurs	Peuvent se mesurer dans le sens direct dans la gamme 2 k Ω , dans le sens inverse dans les gammes supérieures.		

2.2. CARACTERISTIQUES GENERALES

Conditions ambiantes	suitant CEI 359
Conditions climatiques	groupe I avec relèvement de la limite supérieure de température à +50 $^{\circ}$ C. Température ambiante 23 $^{\circ}$ C \pm 2 $^{\circ}$ C Gamme d'utilisation 0 $^{\circ}$ C ... 45 $^{\circ}$ C Gamme limite de stockage et de transport -40 $^{\circ}$ C ... +70 $^{\circ}$ C Humidité relative 20% ... 80% (condensation exclue)

Conditions mécaniques	Groupe II
Conditions d'alimentation	Groupe II Secteur 220 V +10 -12%
	<u>Remarque:</u> Le câblage du transformateur d'alimentation peut être à adapté à une tension secteur de 110 V +10 -12%.
	Fréquence secteur 48 - 65 Hz
	Alimentation pour batterie à l'aide du PM 9216
	Consommation environ 12 VA
Classe de sécurité	Classe I suivant CEI 348
Système de conversion	Modulation delta
Lecture maximum	1999
Nombre de digits	3½
Commande d'affichage	Séquentielle; fréquence d'analyse ≈ 500 Hz
Temps de changement de gamme	0,5 sec./gamme
Temps de conversion	0,4 sec.
Temps de réponse	Dans les gammes courant continu et alternatif: 0,6 sec. avec réglage en 5 sec. max. Dans les gammes de kΩ et MΩ 0,9 sec. avec réglage en 8 sec. max.
Réglage descendant	< 0180
Réglage ascendant	> 1999
Représentation du résultat et polarité	Diodes LED à sept segments
Sélection des gammes	Automatique
Sélection des fonctions	Manuelle, par boutons-poussoirs
Indication de dépassement de gamme	L'indicateur des centaines affiche 0, les autres sont éteints
Virgule	Positionnée automatiquement par le sélecteur de gamme
Entrée de mesure	Flottante
Capacité entre neutre et terre	1,8 nF
Dérive du zéro	± 150 ppm/°C
Tension maximales d'entrée	Gamme
	V $\overline{=}$ 1000 V continu 600 V alternatif (50 Hz)
	V \sim 500 V continu 600 V alternatif (100 Hz)
	kΩ/MΩ 250 V continu ou alternatif
	<u>Remarque:</u> Dans les gammes 0,2 kΩ et 2 kΩ, un fusible fonctionne si la tension d'entrée dépasse 30 V continu ou alternatif.
Dimensions	
	Hauteur 95 mm
	Largeur 235 mm
	Profondeur 280 mm
Poids	Environ 2,0 kg

3. ACCESSOIRES

3.1. FOURNIS AVEC L'INSTRUMENT

- Câble secteur à 3 conducteurs
- Jeu de cordons de mesure avec pointes de touche PM 9260
- 1 Fusible 80 mA temporisé (secteur 220 V)
- 2 Fusibles 160 mA temporisés (secteur 110 V)
- 1 Fusible 125 mA
- Etiquette 110 V
- Couvercle
- Manuel

3.2. EN OPTION

3.2.1. Sonde THT PM 9246 (Fig. 1, page 30)

La sonde THT PM 9246 convient pour la mesure des tensions continues jusque 30 kV. Elle est utilisable avec les instruments de mesure à impédance d'entrée de 100 M Ω , 10 M Ω ou 1,2 M Ω (sélectionnable sur la sonde).

Tension maximum	30 kV
Atténuation	1000 x
Impédance d'entrée	600 M Ω \pm 5%
Précision	\pm 3% pour les instruments à impédance d'entrée de 10 M Ω et 1000 M Ω
Humidité relative	20% . . . 80%

3.2.2. Shunt PM 9244 (Fig. 2, page 30)

Ce shunt permet de mesurer l'intensité de courants continus et alternatifs (1 kHz maxi) de jusque 31,6 A.

Gammes d'intensité	10 A et 31,6 A
Tension de sortie	100 mV et 31,6 mV
Précision	100 mV : \pm 1% 31,6 mV : \pm 2%
Dissipation	31,6 W maxi
Dimensions	Hauteur 55 mm Largeur 140 mm Profondeur 65 mm

3.2.3. Sonde HF PM 9210 Accessoires de sonde PM 9212 (Fig. 3, page 30)

	<u>PM 9210</u>	<u>PM 9210 + PM 9212</u>
Gamme de fréquence	100 kHz ... 1 GHz	100 kHz ... 1 GHz
Ligne droite dans les 5%	100 kHz ... 6 MHz	100 kHz ... 6 MHz
Déviations maxi	3 dB	3,5 dB
Gamme de tension	150 mV ... 15 V	15 V ... 200 V

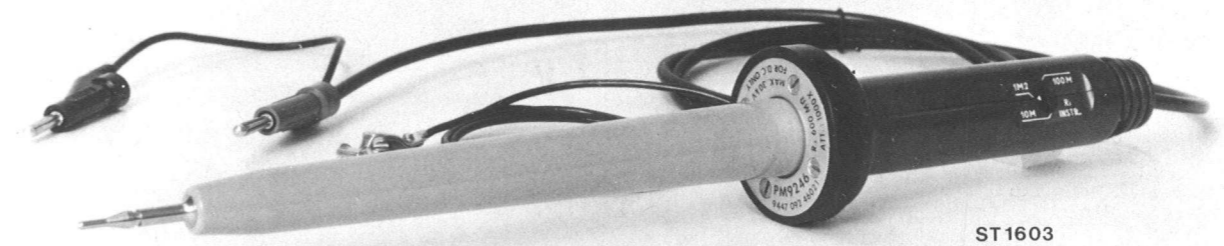

Fig. 1.



Fig. 2.

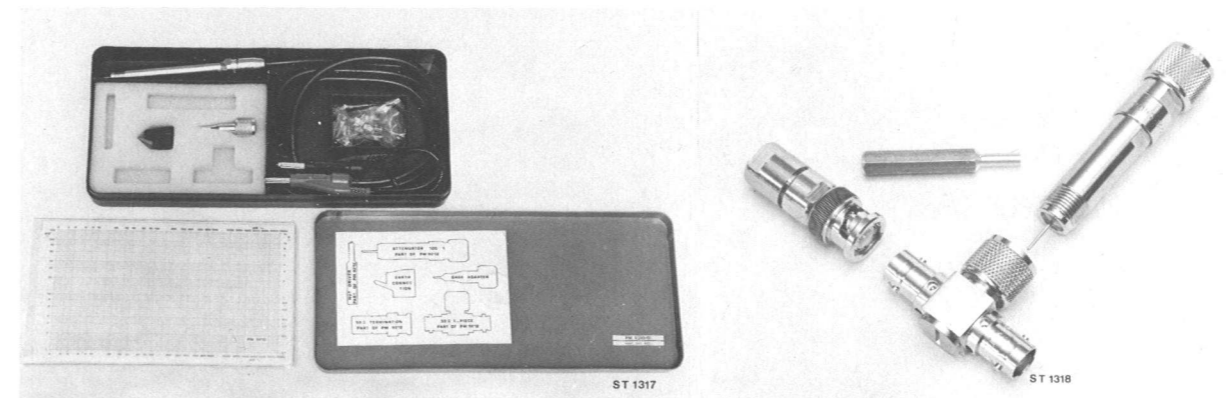

Fig. 3.

	<u>PM 9210</u>	<u>PM 9210 + PM 9212</u>
Tension maximale alternatif	30 V	200 V
Tension maximale courant	200 V	500 V
Capacité d'entrée	2 pF	2 pF
Connecteur T	En option	
Gamme de fréquence		100 kHz ... 1,2 GHz
Impédance		50 Ω
Rapport d'amplitude		1,25 à 700 MHz; 1,15 à 1 GHz

Associée à ses accessoires (broche de mise à la terre réglable et connecteur Dage), la sonde PM 9210 convient jusqu'à la fréquence de 100 MHz.

Pour les mesurer au-delà de cette fréquence, il est recommandé d'employer le T de 50 Ω et la résistance terminale de 50 qui font partie du jeu d'accessoires de sonde PM 9212.

3.2.4. Chargeur de batterie PM 9216

Ce chargeur de batterie peut se fixer à l'arrière de l'instrument. Les batteries sont chargées par l'intermédiaire des circuits d'alimentation de l'instrument.

Tension nominale	5 V
Capacité	3,5 Ah
Courant de charge maximum	350 mA
Courant maximum de charge continu	35 mA
Temps de fonctionnement avec le PM 2523, assuré par une charge	6 h
Temps de recharge	15 h

4. PRINCIPE DE FONCTIONNEMENT (Fig's 4 et 5, page 34)

4.1. CIRCUIT D'ENTREE

Le rôle du circuit d'entrée est de fournir une tension continue de 2 V à l'entrée du convertisseur analogique-numérique, aux valeurs maximales de gamme. Les sections analogiques réfèrent tous les signaux d'entrée, c'est à dire les tensions alternatives et continues et les résistances, à ce signal de 2 V. Le même diviseur est employé pour les tensions continues et alternatives. Le signal atténué est transmis à une amplificateur de 1x ou 10x à sortie de 2 V continu ou 2 V_{eff} alternatif. En cas de mesure de tensions alternatives, la sortie de l'amplificateur est redressée par un convertisseur alternatif/continu, et de résistance. Pour la mesure des résistances, la résistance inconnue est traversée par un courant d'intensité constante, conformément au tableau ci-dessous.

Gammes	Courant	Tension de mesure (au max de gamme)
0,2 kΩ	1 mA	0,2 V
2 kΩ	1 mA	2 V
20 kΩ	10 μA	0,2 V
200 kΩ	10 μA	2 V
2000 kΩ	100 nA	0,2 V
0,2 MΩ	10 μA	2 V
2 MΩ	100 nA	0,2 V
20 MΩ	100 nA	2 V

La tension de mesure de la résistance inconnue est transmise au convertisseur analogique-numérique via l'amplificateur 1x ou 10x.

4.2.

SECTION NUMERIQUE

Le convertisseur analogique-numérique de PM 2523 est basé sur le principe de la modulation delta. Ce système d'intégration assure une bonne linéarité et une bonne réjection mode série. De plus, le circuit contient un minimum d'éléments critiques, la précision de la tension de référence n'ayant d'importance que pour la précision du convertisseur analogique-numérique. Le principe de base du convertisseur analogique-numérique employé dans le PM 2523 est illustré par la figure 4, page 34. FF est un basculeur bistable dont la sortie actionne un interrupteur chopper qui connecte R à une tension de référence soit positive, soit négative. L'état du basculeur dépend du niveau de la tension d'entrée D au moment d'une impulsion d'échantillonnage fs. Le niveau de la tension d'entrée D dépend de l'état de charge du condensateur C. Supposons que, au moment d'une impulsion fs, le niveau de tension en D soit inférieur au point de travail du basculeur. Le résultat est que la tension de sortie du chopper diminue et qu'une tension de référence négative est fournie à l'intégrateur via R. La tension de sortie de l'intégrateur s'élève parce que V_{ref} > V_i dans la gamme de graduation. La tension de sortie est donnée par :

$$V_{Dc} = -\frac{RC}{1} (V_i - V_{ref}) \quad (1)$$

(tc étant le temps de charge)

$$V_{Dd} = -\frac{RC}{1} (V_i - V_{ref}) \quad (2)$$

(td étant le temps de décharge)

Chaque impulsion d'échantillonnage successive fs provoque l'échantillonnage de V_D et, lorsque V_D dépasse le seuil de fonctionnement du basculeur, ce dernier change d'état. L'intégrateur est alors connecté à +V_{ref}. La tension de sortie de l'intégrateur diminue alors. Elle est donnée par :

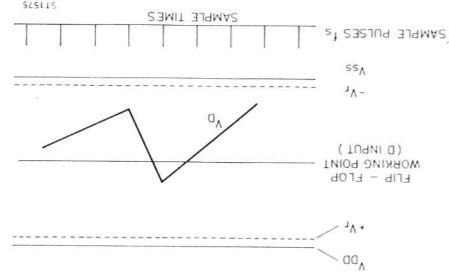
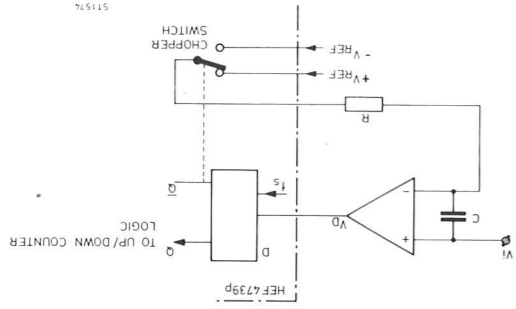

Fig. 4.

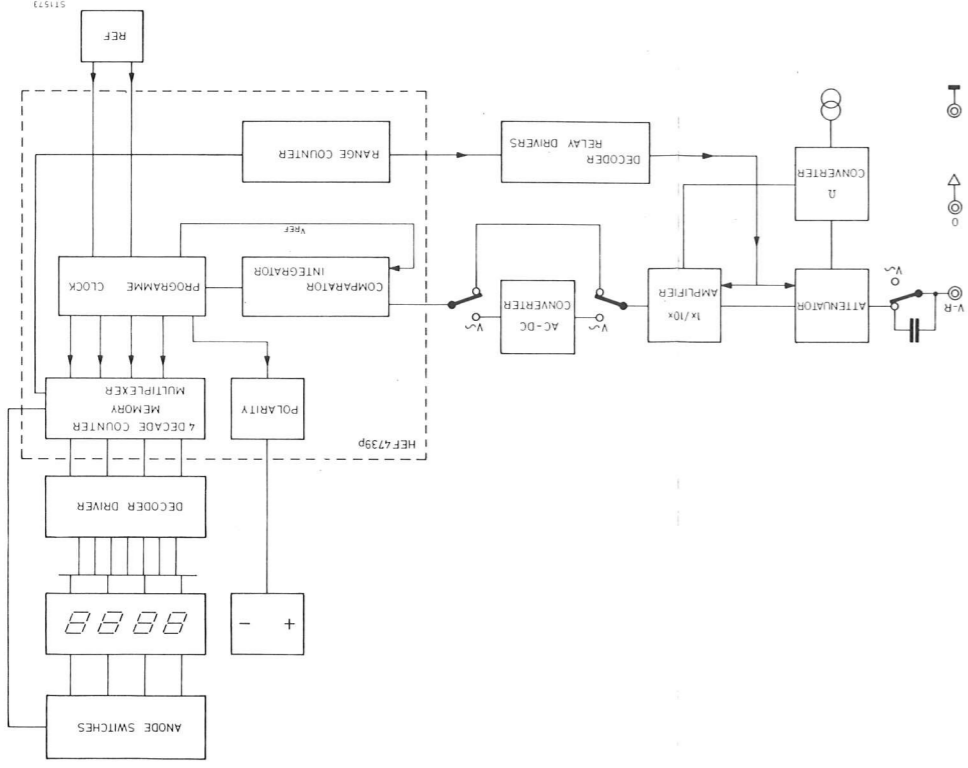

Fig. 5.

On constate que si $V_i > 0$, la pente résultant de l'équation (1).

Etant donné que $V_{ref} > V_i$ est une condition, les équations (1) et (2) montrent le signe de la pente change lors de la commutation du chopper. La tension de sortie de l'intégrateur est donc la forme d'onde en dents de scie représentée sur la figure 4 pour une tension d'entrée positive. On déduit en outre des équations (1) et (2) qu'avec une tension d'entrée négative, les pentes sont inversées, c'est à dire que la pente positive devient la plus rapide.

La réaction digitalisée limite la charge du condensateur C, de sorte qu'on obtient un équilibre de charge entre la tension d'entrée et la tension de référence.

Grâce à cette méthode de compensation, la valeur moyenne de VD ($VD_c + VD_d$) est égale à V_i . Il en résulte

$$V_i = \frac{tc - td}{tc + td} V_{ref} \quad (3)$$

tc + td = tm (temps de mesure).

Soit N = nombre total d'impulsions fs pendant tm

n = nombre total d'impulsions fs pendant tc.

On peut alors écrire l'équation (3) sous la forme

$$V_i = \frac{n - (N - n)}{N} V_{ref} = \frac{2n - N}{N} \quad (4)$$

On emploie un compteur bidirectionnel pour compter en accroissement lorsque l'intégrateur est connectée sur +V_{ref}. à rebours s'il est connecté sur -V_{ref}. Au bout de N échantillonnage, le compteur est au niveau 2n - N. Dans le GZF 1200 utilisé, N = 4096 et V_{ref} = 2,048 V. pour que l'affichage obtenu soit stable, le contenu de l'intégrateur est divisé par deux et transféré dans une mémoire, après quoi le compteur est remis à zéro. Une nouvelle mesure peut alors commencer.

Une multiplexeur connecte successivement chaque décade de la mémoire au décodeur driver. Une impulsion est émise simultanément pour actionner le commutateur d'anode du LED à sept segments correspondant. Par l'intermédiaire du décodeur driver, l'information décodée est transférée aux indicateurs à LED mentionnés, dont les cathodes sont branchées en parallèle.

Seul s'allume l'indicateur dont l'interrupteur d'anode est fermé. Si le nombre des impulsions comptées dépasse 2000, le compteur de gamme passe à sa position suivante, il y a mise en circuit de la gamme immédiatement supérieure et un nouveau cycle de mesure commence automatiquement.

Le passage à la gamme immédiatement inférieure s'effectue si 0180 impulsions ou moins sont comptées au cours d'un cycle de mesure.

5. MISE EN PLACE

MODE D'EMPLOI

Avant d'effectuer aucun branchement, il faut relier la borne de terre à un conducteur approprié (voir chapitre "MISE A LA TERRE").

5.1. SECTEUR ET FUSIBLE

Avant d'enfoncer la fiche secteur dans la prise, s'assurer que l'instrument est réglé sur la tension secteur locale. L'instrument est câblé pour fonctionner sur **220 V - 50 Hz**.

5.1.1. Adaptation à la tension secteur

En connectant les enroulements du transformateur comme le montre la figure 6, page 38, on peut adapter l'instrument aux tensions suivantes:

220 V +10% -12% ... 50/60 Hz, fusible: 80 mA, temporisé

110 V +10% -12% ... 50/60 Hz, fusible: 160 mA, temporisé

Remarque: Si on adapte le câblage du transformateur à un secteur de 110 V, coller sur l'arrière de l'instrument l'étiquette correspondante comprise dans la fourniture.

5.1.2. Fusible
Le fusible secteur se trouve sur la plaquette à circuit imprimé, à gauche au transformateur (figure 6, page 38). Pour remplacer le fusible secteur, enlever le couvercle supérieur (voir section "ACCES").

5.1.3. Généralités

L'adaptation éventuelle à la tension secteur locale ne doit être effectuée que par une personne compétente, consciente des risques que cela entraîne.
Pour remplacer un fusible ou adapter l'instrument à une autre tension secteur, il faut le débrancher de toutes les sources de tension.

5.2. ALIMENTATION PAR BATTERIE

Il est recommandé d'employer l'accessoire en option PM 9216 pour l'alimentation par batterie, car il s'intègre totalement à l'instrument.

5.2.1. Montage du PM 9216

- Ouvrir le couvercle du compartiment de batterie du multimètre
- Enfoncer la fiche d'alimentation sur batterie à la fiche de batterie du multimètre
- Placer le PM 9216 dans le compartiment de batterie.
- Les deux crochets du PM 9216 doivent être placés dans les deux fentes "A" correspondantes (figure 6, page 38) du compartiment de batterie.
- Fixer le PM 9216 par serrage des deux vis fournies dans les trous appropriés.

5.3. MISE A LA TERRE

Avant de mettre l'instrument en circuit, on devra le connecter à un conducteur de terre de l'une de manière suivantes:

- via le câble secteur à trois conducteurs. La fiche secteur devra être branchée sur une prise équipée d'un contact de terre. On ne devra pas rendre cette protection inefficace par l'emploi d'un cordon prolongateur sans conducteur de protection. Le changement de fiches secteur est aux risques et périls de l'utilisateur.

ATTENTION

Toute coupure du conducteur de protection à l'intérieur ou à l'extérieur de l'instrument ou à la borne de terre est de nature à rendre l'instrument dangereux. De telles opérations sont interdites.
La condensation qui se produit lorsqu'on transfère l'instrument d'un endroit froid à un endroit chaud est source de danger.
Il faut donc veiller à ce que la mise à la terre soit correcte.

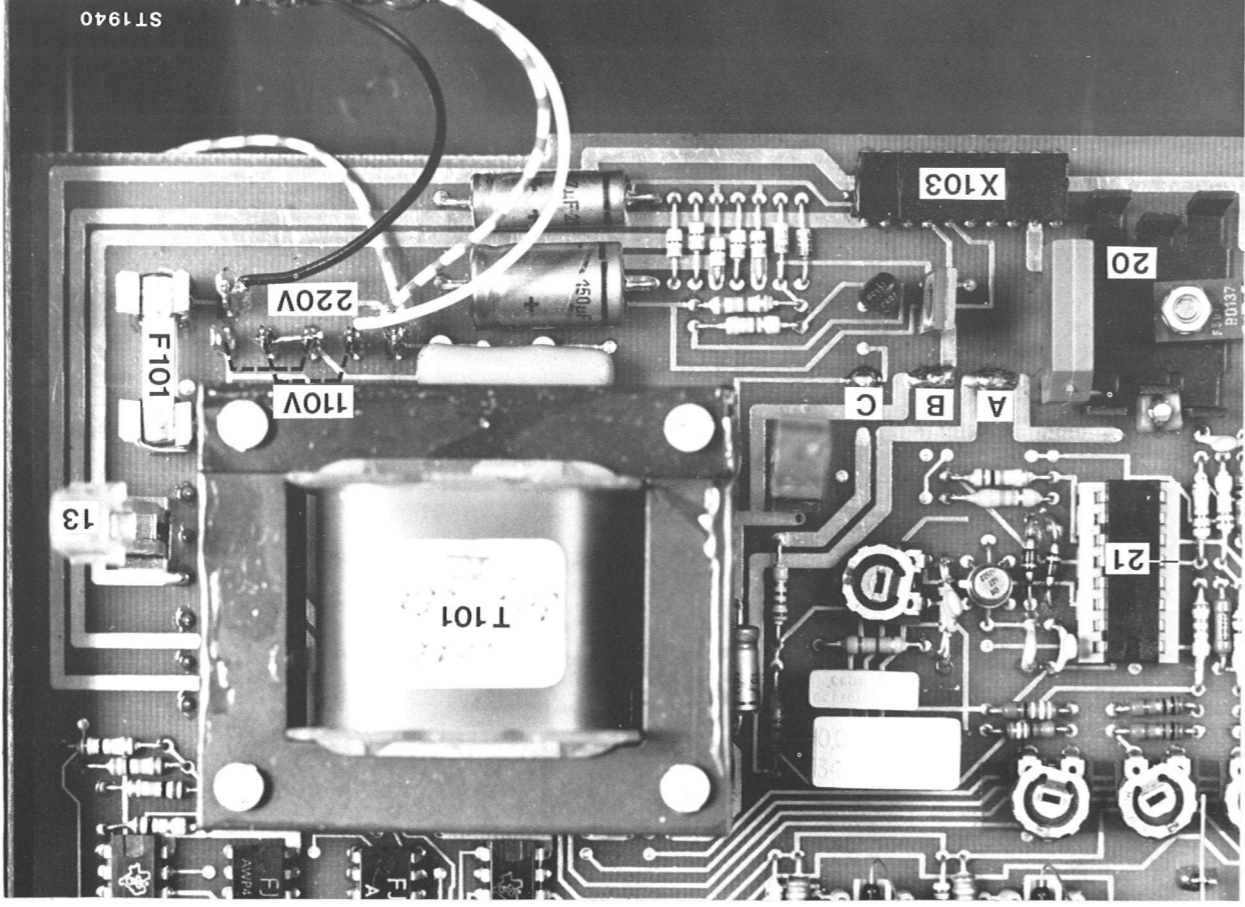

Fig. 6.



Fig. 7.

6. UTILISATION

6.1. MISE EN CIRCUIT

L'instrument est prêt à fonctionner une fois qu'il est branché sur le secteur et mis à la terre. On le met en circuit à l'aide du bouton-poussoir POWER (Figure 8, page 42).

6.2. COMMANDES

6.2.1. Panneau avant (Fig. 8, page 42)

Repère	Symbole	Fonction
S101	POWER	Mise de l'instrument en circuit
S102	$V \equiv$; $V \sim$; $k\Omega$; $M\Omega$	Choix de la fonction de mesure requise
S1	DATA HOLD	Maintien de la valeur affichée
X2	RANGE HOLD	Maintien de gamme
X3	\perp	Borne de terre
X4	0	Borne d'entrée basses tensions
X4	$V\Omega$	Borne d'entrée hautes tensions combinée pour mesure de tensions et de résistances
R1	"0"	Réglage du zéro

6.2.2. Panneau arrière (Fig. 7, page 38)

Repère	Symbole	Fonction
X1		Alimentation secteur
X103		Alimentation par batterie

6.3. REGLAGE DU ZERO

Laisser l'appareil s'échauffer pendant 30 minutes avant d'effectuer le réglage du zéro.

- Enfoncer le bouton $V \equiv$
- Court-circuiter les bornes $V\Omega$ et 0
- Régler la valeur affichée sur .0000 \pm digit à l'aide de R1 ("0").

Remarque: Pour des réglages complets, voir le chapitre "Checking and adjusting".

6.4. MESURE

6.4.1. Choix de la fonction

La fonction de mesure se choisit à l'aide sélecteur de fonction.

V _{cc}	100 µV	...	1000 V _{cc}
V _{eff}	100 µV	...	600 V _{eff}
kΩ	0,1 Ω	...	2000 kΩ
MΩ	0,1 kΩ	...	20.00 MΩ

6.4.2. Mesure de tensions continues

— Enfoncer le bouton V_{cc}

— Connecter la tension d'essai sur les borne "0" et "V_Ω"

Remarques: — L'indicateur de polarité indique la polarité à la borne "V_Ω" par rapport à la borne "0"

— La tension maximum admissible entre les bornes "V_Ω" et "0" est 1000 V_{cc} ou 600 V_{ca} (50 Hz).

6.4.3. Tension THT jusque 30 kV avec la sonde PM 9246

— Enfoncer le bouton V_{cc}

— Connecter la sonde aux bornes "0" et "V_Ω" (les bornes "0" et "┴" doivent être interconnectées).

— Fixer la pince de la sonde de la terre en un endroit approprié.

— Choisir la gamme 10 MΩ sur la sonde.

Remarques: — Tension continue maximum admissible 30 kV (le maxi de la gamme est 100 kV)

— Tenir compte de la position de la virgule.

6.4.4. Mesure de tensions alternatives

— Enfoncer le bouton V_~

— Connecter la tension à mesurer aux bornes "0" et "V_Ω"

Remarque: — La tension maximum admissible entre les bornes "V_Ω" et "0" est 500 V_{cc} en continue ou 600 V_{ca} en alternatif (100 Hz).

6.4.5. Tensions UHF avec sonde PM 9210 et T PM 9212

— Enfoncer le bouton V_~

— Connecter la sonde aux bornes "0" et "V_Ω", la broche de terre sur "0" (les bornes "0" et "┴" doivent être interconnectées).

Remarques: — La tension maximum admissible sur la sonde (avec atténuateur) est 200 V_{eff}, superposée à 500 V_{cc} en continu.

— Il faut tenir compte du coefficient de correction sur la courbe d'étalonnage de la sonde.

6.4.6. Mesure de résistances

— Enfoncer le bouton kΩ ou MΩ

— Connecter la résistance à mesurer aux bornes "0" et "V_Ω"

Remarques: — Le courant de mesure est: 1 mA pour les gammes 200 Ω et 2 kΩ

10 nA pour les gammes 20 kΩ et 200 kΩ

100 nA pour les gammes 2 MΩ et 20 MΩ



Fig. 8.

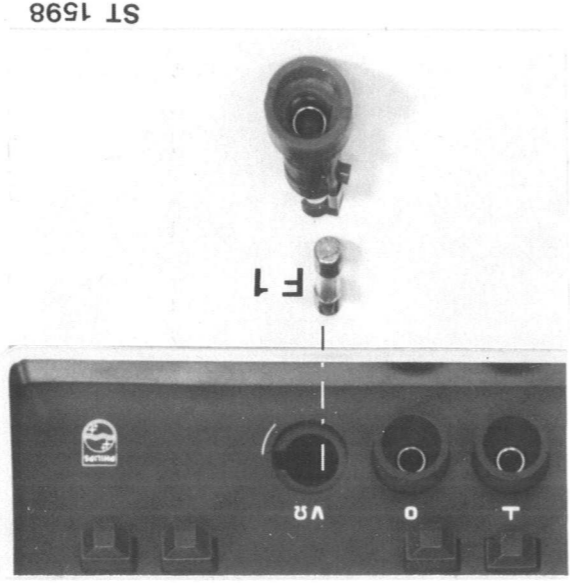

Fig. 9.

6.4.7. Diodes

- Enfoncer le bouton $k\Omega$
- Connecter la diode dans le sens direct aux bornes "0" et " $V\Omega$ "
- Court-circuiter la diode jusqu'à atteindre la gamme la plus basse
- L'instrument affiche la tension de la diode le sens direct pour 1 mA
La borne " $V\Omega$ " est positive par rapport à la borne "0".

6.5. REMARQUES GENERALES

6.5.1. Maintien de gamme

Si on enfonce le bouton "RANGE HOLD", la gamme utilisée alors est maintenue et la position de la virgule fixée. Le dispositif de changement automatique de gamme est bloqué.

Exemple:

Entrée	Valeur affichée	Bouton de maintien de gamme
0 V	.0000	–
+19.99 V	+19.99	–
+19.19 V	+19.19	Enfoncé
0 V	00 . 00	Enfoncé

6.5.2. Maintien d'affichage

Si on enfonce le bouton "DATA HOLD", il y a maintien de la valeur affichée à ce moment par l'instrument.

6.5.3. Indication de dépassement de gamme

En cas de dépassement de gamme, l'indicateur LED des centaines affiche 0, les autres sont éteints. Il y a

Il y a indication de dépassement de gamme chaque fois que:

- Le signal d'entrée dépasse une gamme de mesure **maintenue**.
- On enfonce le bouton $k\Omega$ ou $M\Omega$ alors que les bornes d'entrée sont ouvertes ou que l'on connecte une résistance supérieure à $20 M\Omega$.

7. CIRCUIT DESCRIPTION

SERVICE DATA

7.1. THE CIRCUIT DESCRIPTION IS LOGICLY SUBDIVIDED IN TWO MAIN SECTIONS

- a) The analogue section } see Fig. 10
- b) The digital section }

Each section is described separately with reference to the overall circuit diagram. In addition circuit diagrams of the various stage have been inserted in text as appropriate to assist the circuit diagram.

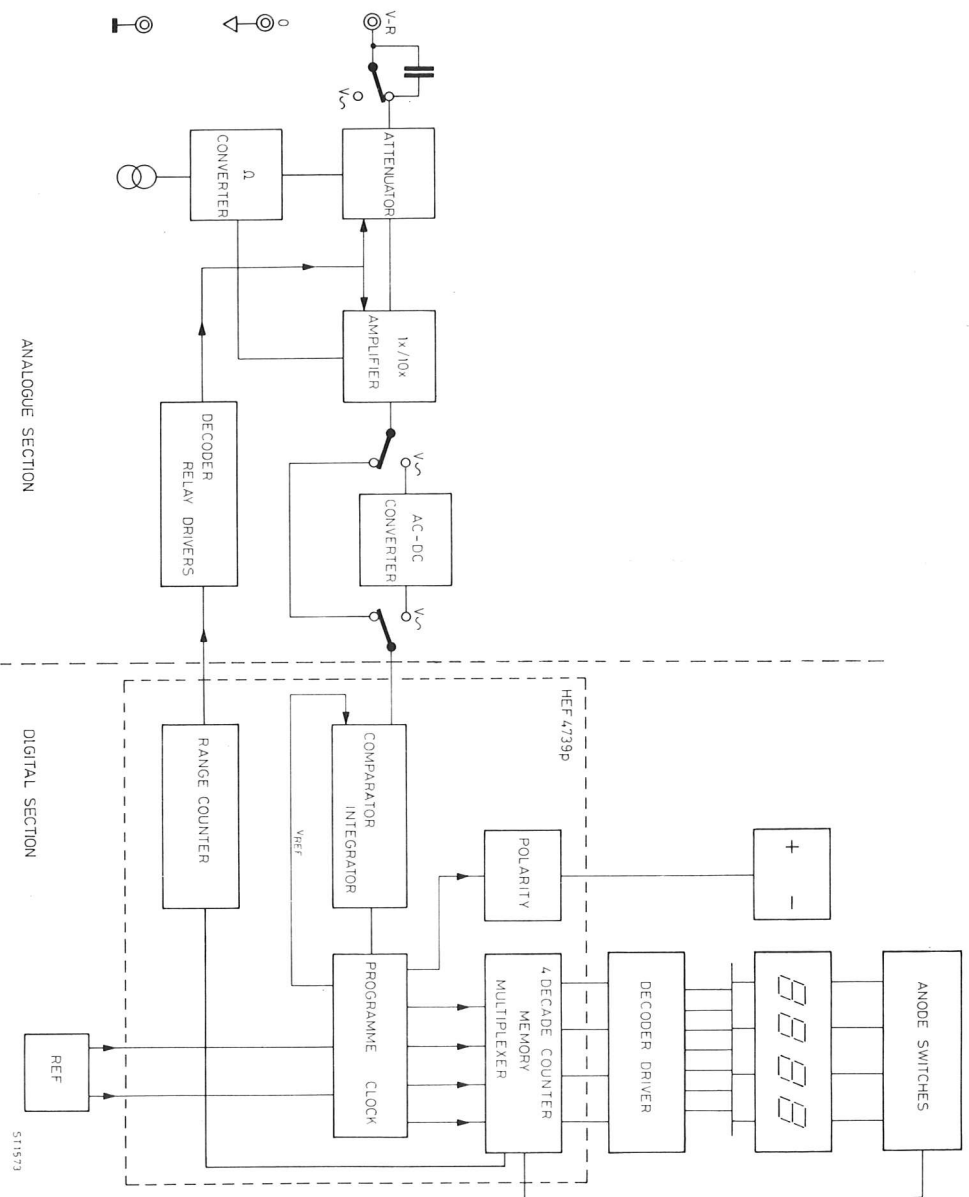

Fig. 10. Block diagram PM 2523

7.1.1. Analogue section (see Fig. 11, page 47)

7.1.1.1. Principle of operation

The analogue section serves to take the input voltage or resistance to be measured and translate it into a suitable form for the ADC input i.e. a direct voltage having a 2 V end of range value.

All voltages to be measured, whether a.c. or d.c. use the same attenuator/divider network. The attenuated signal is fed to a x1 or x10 amplifier, depending on the range, which gives a maximum output of 2 V d.c. or 2 V_{rms}.

For a.c. voltage measurements, the output of the amplifier is rectified by an AC-DC convertor, which is switched off for d.c. voltage and resistance measurements. The rectified d.c. voltage (2 V end of range) is then applied to the ADC. (= Analogue to Digital Converter)

For resistance measurements a constant current passes through the unknown input resistance, the value of the current being in accordance with the selected range. The measured voltage across the unknown resistance is supplied to the ADC via a x1 or x10 amplifier.

7.1.1.2. D.C. voltage circuit (Fig. 12, page 47)

The input voltage to be measured is applied via the fuse F101, and the mode selector switch contacts that by-pass capacitor C101 to the attenuator network.

Relay contacts K1, K2 and K3 selects the appropriate portions of the attenuator network, under the control of the range decoder relay drivers in the digital section.

Relay contact K4 also controlled by the range decoding circuits, selects the x10 amplification factor of the x1 x10 amplifier on attenuated ranges. This amplifier ensures an end of range voltage of 2 V at the input to the ADC and obviated the need for a different attenuator network for each range.

The attenuation for the various ranges is given in the table below.

RANGE	ATTENUATION	RANGE CONTACTS CLOSED	x1 x10 AMPLIFIER	
			INPUT VOLTAGE (End of range)	GAIN
0,2 V	1	K1, K4	0,2 V	x10
2 V	1	K1	2 V	x1
20 V	100	K2, K4	0,2 V	x10
200 V	100	K2	2 V	x1
1000 V	10,000	K3, K4	0,2 V	x10

7.1.1.3. Input filter circuit (Fig. 13, page 47)

The input filter circuit provides a direct path from the V_Ω front-panel active measuring terminal to the attenuator for the direct voltage and resistance measuring modes.

In the direct voltage mode the push-button V_Ω selector contacts bypass the capacitor C101, C11 is out of circuit, and dependent upon the range selected, the relevant attenuator resistors are connected directly across the input circuit. The mode selector contacts also bypass the filter capacitor C115, which is operative only in the resistance mode.

In the resistance measuring mode, the normal contacts of the V_Ω and V_Ω switches provide a direct path for the constant current reference source to flow via the selected attenuator resistors to the unknown resistance connected to the front-panel V_Ω terminal.

In the a.c. voltage mode, the capacitors C101 and C111 are switched to provide a.c. coupling from the unknown a.c. voltage on the V_Ω terminal to the attenuator. At the higher frequencies the capacitor C111 effectively short-circuit resistors R108 and R109, thus compensating for H.F. losses.

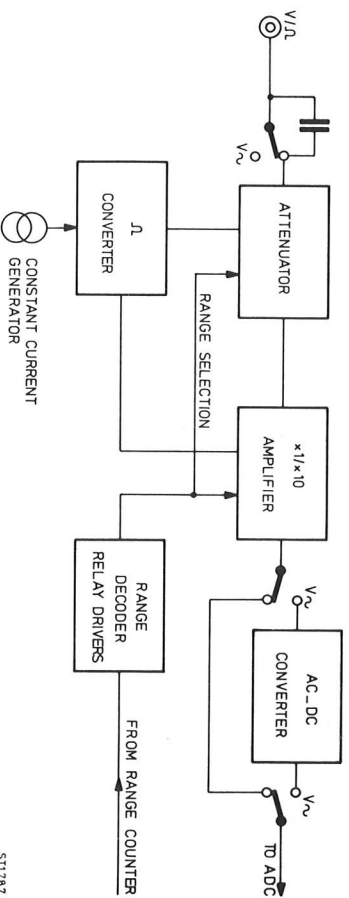

Fig. 11. Block diagram analogue section

517787

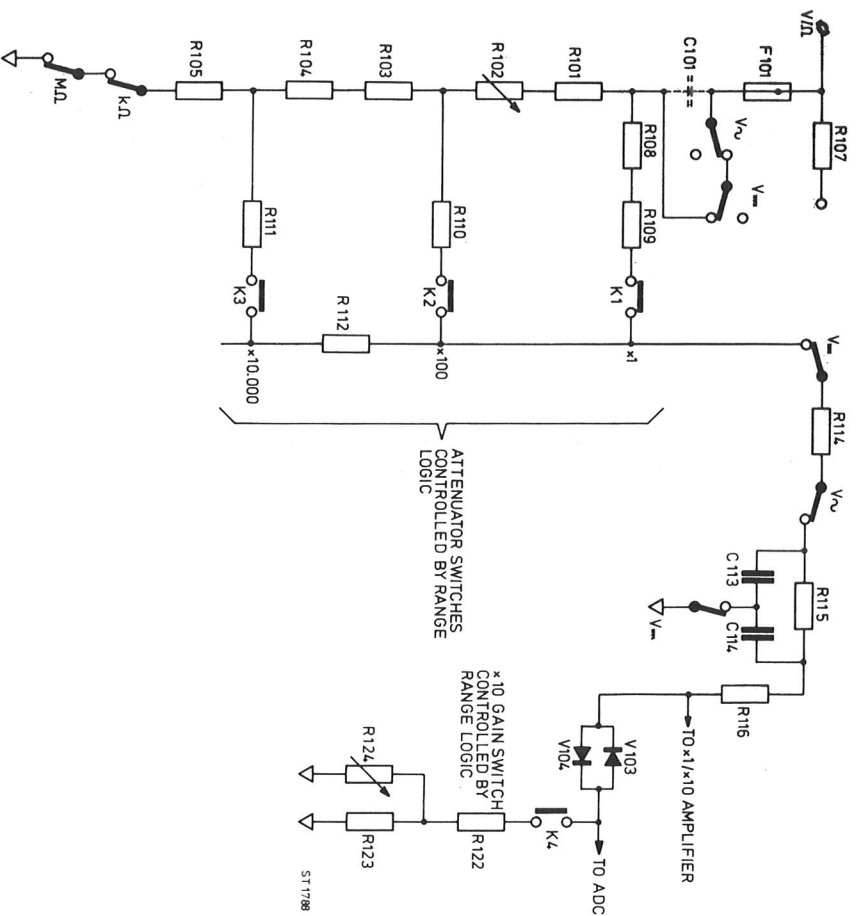

Fig. 12. Input circuit for d.c. voltage

517788

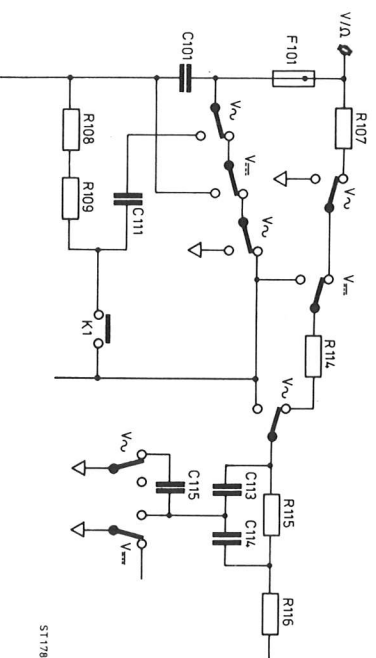

Fig. 13. Input filter

517789

7.1.1.4. x1/x10 Amplifier (Fig. 14, page 49)

This circuit consists of operational amplifier A101 preceded by the dual FET V125, which has a very high input impedance at a low offset current. This amplifier ensures 2 V end of range input to the ADC by providing either a gain of x1 (relay contact K4 open) or a gain of x10 (relay K4 closed).

The offset voltage is compensated for by R117 and potentiometer R11, the front-panel "0" control.

The x10 gain of the amplifier is determined by the $\frac{R_{out}}{R_{in}}$ ratio.

$$\frac{R121 + R122 + R123 // R124}{R122 + R123 // R124} = 10$$

Potentiometer R124 permits the gain to be preset to exactly 10.

For d.c. measurements, capacitors C113 and C114 are connected to the 0 V line via the $V_{\text{---}}$ switch, thus forming, together with R115, and RC filter for a.c. voltage suppression.

For a.c. measurements, capacitors C113 and C114 // R115 give an improvement in the frequency response.

To protect the operational amplifier the current is limited by diodes V103, V104 which are connected back-to-back effectively across the input (see Fig. 15, page 49). The current through the diodes is limited by series resistors R115 and R116.

If the input to the operational amplifier exceeds 9 V (the voltage at point B) these diodes will conduct and provide limiting. The voltage at point B is obtained from two internal zener diodes connected between points 7 and 8. The protection circuit is shown in figure 15, page 49.

7.1.1.5. AC voltage circuit

The input circuit for a.c. voltage measurements is shown in figure 16, page 50. The voltage to be measured is connected via fuse F101 and coupling capacitors C101 and C111 to the attenuator circuit as described in section 7.1.1.3. In principle, the input circuit is similar to that for d.c. measurement except that the attenuator resistors are shunted by capacitors for frequency correction.

Under the control of the range selector logic, relay contacts K1, K2 and K3 determine the attenuation of the resistance network and K4 determines the gain of the x1/x10 amplifier.

The output of the x1/x10 amplifier, 2 V_{rms} at end-of-range, is applied via a buffer stage V126, V127 to the AC-DC convertor A102 which provides a rectified output (2 V end-of-range) to the input of the ADC.

7.1.1.6. Buffer Stage and AC-DC Converter

The output on pin 5 of the x1/x10 amplifier is fed via diode V105 to the base of V126, which is conjunction with V127 forms a buffer stage (Fig. 17, page 49). To compensate for the base-emitter voltage (V_{BE}) of transistor V126, the output of the x1/x10 amplifier is increased by 0.6 V by the use of diode V105. This buffer stage matches the signal to the low input impedance (approx. 4.5 k Ω) of the inverting input of the operational amplifier A102 (see Fig. 18, page 50).

The output of the buffer amplifier is fed via C121 to the series-input gain-determining resistors R136 and R137 of the operational amplifier A102, which has a high open-loop gain to compensate for the non-linear diode characteristics of the conversion network. Potentiometer R136 is preset to given end-of-range calibration. A diode resistor-capacitor network is used for conversion, for the positive half-cycles. The negative half-cycles are only used as a feedback signal.

The gain for positive half-cycles is determined via diode V107 by the ratio of

$$\frac{R_f}{R_{in}} = \frac{R140}{R136 + R137} = 2.22 \text{ (twice the form factor)}$$

Likewise the gain for the negative half-cycles is determined via V106 by the ratio of

$$\frac{R_f}{R_{in}} = \frac{R139}{R136 + R137} = 2.22$$

The output of the positive half-cycle rectification produces an end-of-range voltage of 2 V d.c. .

Any offset is compensated for by preset potentiometer R141.

Fig. 16. Input for a.c. voltage

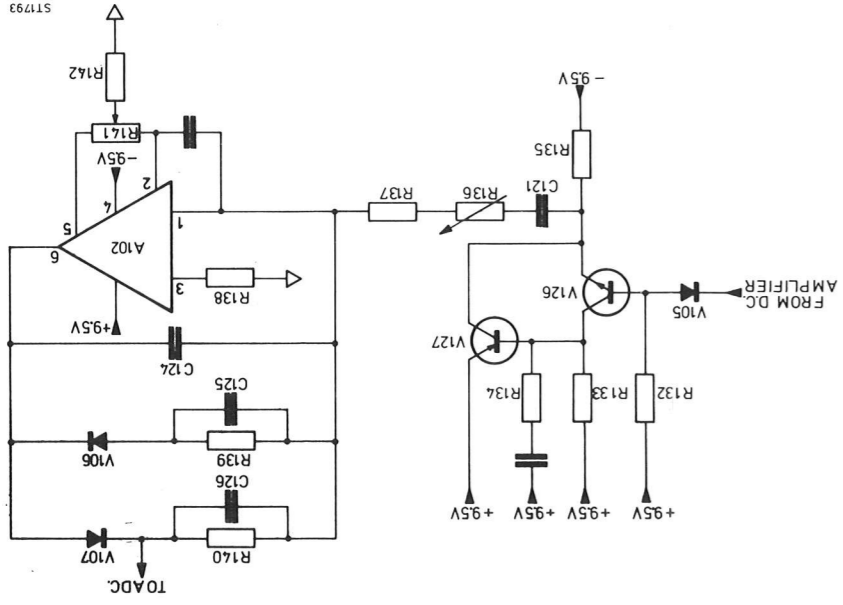
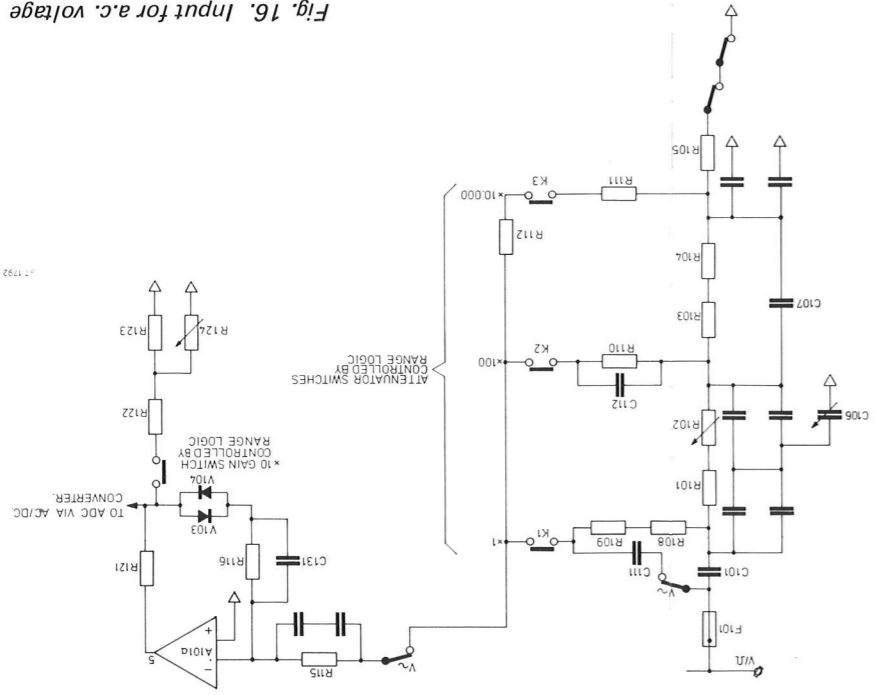

Fig. 18. AC-DC converter

ST1793

Fig. 14. $\times 1, \times 10$ amplifier

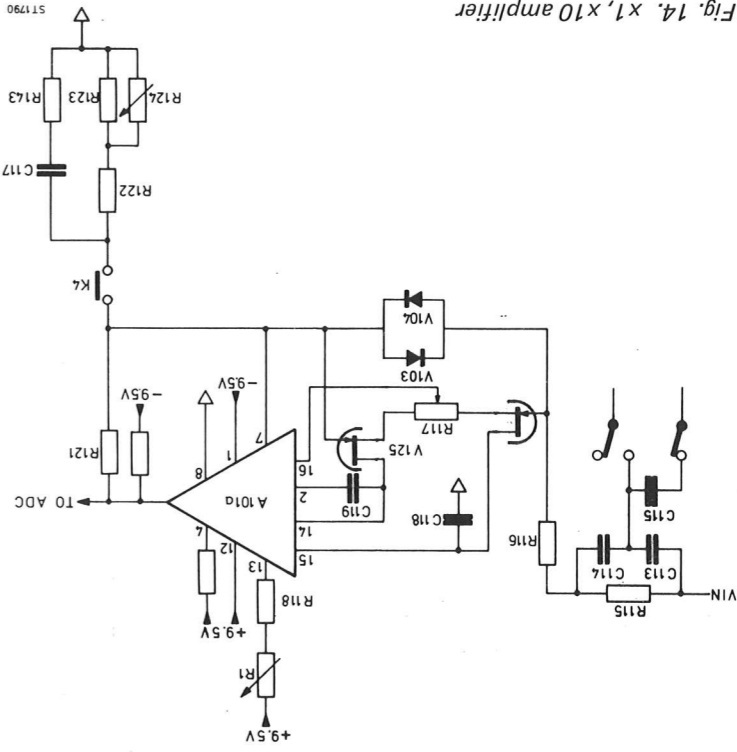

Fig. 15. Protection circuit

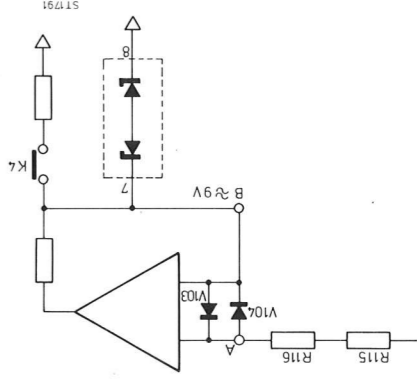
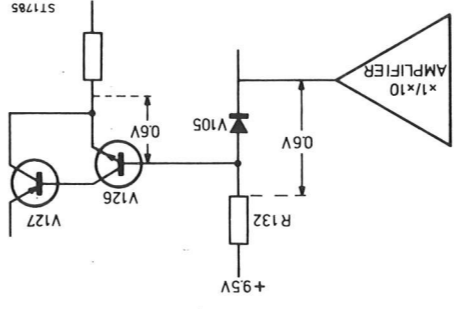

Fig. 17. Buffer stage



7.1.1.7. Resistance measurements

The input circuit for resistance measurements is shown in figure 19. The resistance to be measured is connected via the front-panel $V\Omega$ terminal, fuse F101, and the selected attenuator resistors to a constant current source supplied by A101B. The resulting voltage developed across the unknown resistance is coupled via the normal V pushbutton contacts to the x1/x10 amplifier input where the same principles apply as for d.c. voltage measurements.

The principles of resistance measurements are shown in figure 20. A constant current passes through the unknown resistance R_x to produce a voltage V_x , which is supplied to the + input of the x1/x10 amplifier A101A. Depending on the range, V_x will be amplified by x1 or x10.

The operational amplifier A101B controlled from the output of the x1/x10 amplifier generates an output voltage of approximately 1,25 V across the source resistors R_s (selected range resistors).

This voltage is compensated to exactly 1.2 V by R125/R126 to achieve the same deviation for each range. As V_x is applied to the input of A101B the output will be $1.25 V + V_x$ volts.

As resistor chain R_s causes a drop of 1.25 V, this voltage is independent of V_x and thus of R_x . Therefore, the current through R_x is determined by R_s

The various measuring currents and volts for the selected ranges are given in the following table:

RANGE	R_s	I_m	x1 x10 AMPLIFIER		ADC INPUT
			INPUT VOLTAGE (End of range)	GAIN	
0.2 k Ω	1.2 k Ω	1 mA	200 mV	x10	2 V
2 k Ω	1.2 k Ω	1 mA	2 V	x1	2 V
20 k Ω	120 k Ω	10 μ A	200 mV	x10	2 V
200 k Ω	120 k Ω	10 μ A	2 V	x1	2 V
2000 k Ω	12 M Ω	100 nA	200 V	x10	2 V
0.2 M Ω	120 M Ω	10 μ A	2 mV	x1	2 V
2 M Ω	12 M Ω	100 nA	200 V	x10	2 V
20 M Ω	12 M Ω	100 nA	2 V	x1	2 V

All resistance ranges can with stand 250 V d.c. or a.c. In the event of incorrect operation in the 0.2 k Ω and 2 k Ω ranges, fuse F101 will blow. The voltage is limited by two zener diodes V101 and V102, the zener current being limited by R112.

The other resistance ranges are inherently protected because the current is reduced due to the very high value of the R_s chain (120 k Ω and 12 M Ω).

Diodes are measured in forward direction in the 2 k Ω range.

7.1.1.8. Reference voltages (Fig. 21, page 53).

Two reference voltages of +2.046 V and -2.046 V are required for the ADC. These are obtained from the +9.5 V rails respectively and, apart from the polarity of the zener diodes, the two potential divider networks are identical. The constant current flowing through the zener diodes results a constant voltage.

Adjustment presets for the zener current, the reference voltage, and the 2 V end-of-range are indicated on the diagrams.

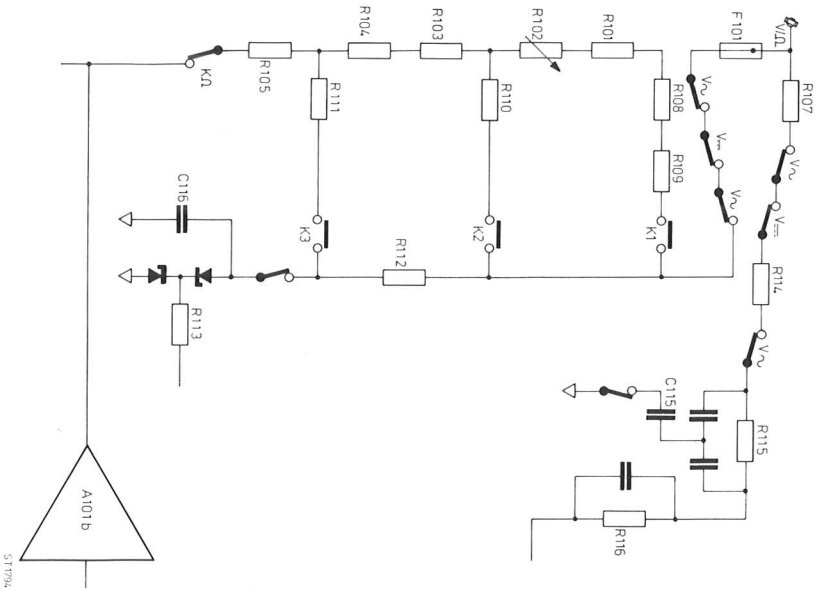

Fig. 19. Input circuit for $K\Omega$ range

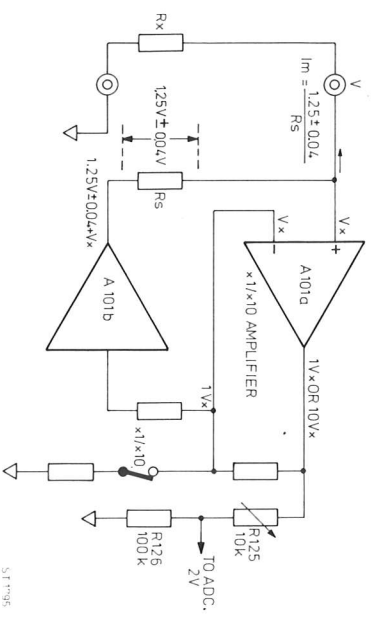

Fig. 20. Principle resistance measurement

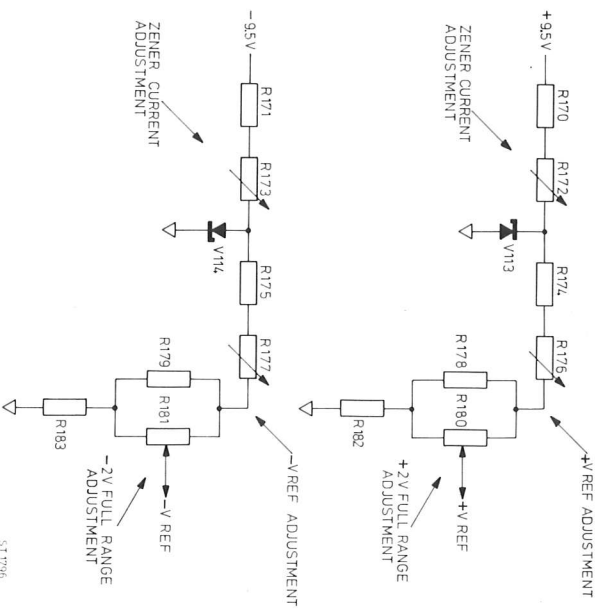

Fig. 21. + and - reference voltages

7.1.2. Digital section

7.1.2.1. Principles of operation

The digital section is designed to accept the d.c. voltage (2 V end-of-range) from the analogue section and convert it into a digital form suitable for display and for range-changing purposes.

The blockdiagram of the digital section is given in figure 22.

The 2 V d.c. end-of-range from the analogue section is filtered (V128) and passed to the ADC where it is compared with a switched reference voltage. The resultant voltage is used to charge a capacitor in the integrator circuit (A103) to produce a sawtooth voltage. Thus the sawtooth changes state at a point dependent upon the magnitude of the input voltage. Pulses from a programme clock that sample the capacitor charge time provide a digital representation of the analogue input.

These pulses are counted in a 4-decade up/down counter and transferred to a buffer memory, and the counter is reset for the next conversion. A multiplexer routes each decade to the decoder driver D201. The 7-code signals are applied to all four of the displays, but only the appropriate anode switch is activated by the counter. The number of pulses from the up/down counter is sampled in a results detector to determine when ranging should occur and for overload indication.

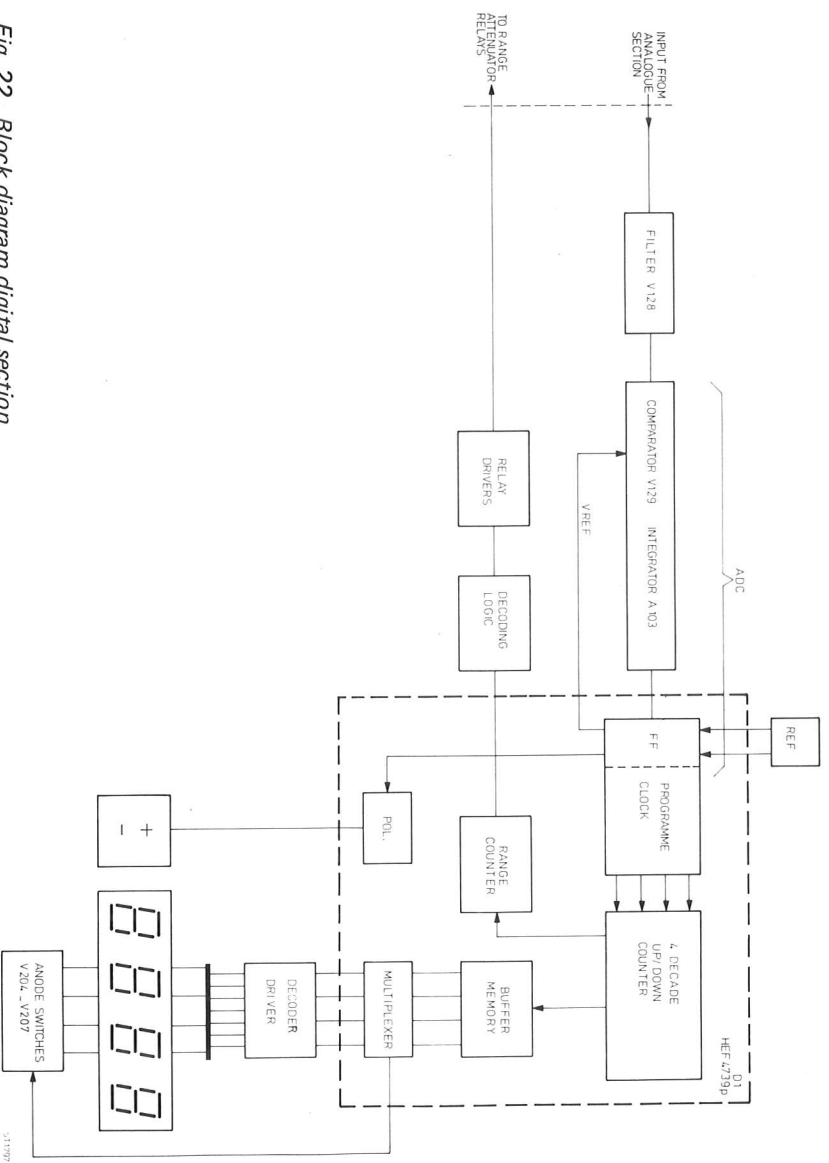

Fig. 22. Block diagram digital section

7.1.2.2. Analogue-to-digital convertor (ADC)

The ADC is based on the principle of delta-pulse modulation (Fig. 4, page 34). This integrating system ensures good linearity and series mode rejection. In addition, the circuit contains a minimum of critical elements, the accuracy of the ADC being dependent only on the accuracy of the reference voltage.

The output of flip-flop FF operates a chopper switch to connect the negative input of the integrator via R to either a positive or a negative reference voltage.

The state of the flip-flop depends on the level of the D input at the time of a sample pulse f_s . In turn, the level of the D input depends on the state of charge of capacitor C.

Assume that, at the instant of a pulse f_s , the voltage level at D is below the flip-flop working point. This results in a low output from the chopper and a negative reference voltage is connected to R. The input voltage V_i and the reference voltage V_{ref} are both applied to the integrator/comparator. Because V_{ref} is greater than V_i within the scale range, the integrator output voltage increases and is given by:

$$V_{Dc} = -\frac{1}{RC} (V_i - V_{ref}) \quad t_c \quad (1)$$

where t_c is the charging time.

At each succeeding sample pulse f_s , V_D is sampled and when V_D exceeds the flip-flop working point the flip-flop changes its state. The integrator is then connected to the $+V_{ref}$, its output falls and is given by:

$$V_{Dd} = -\frac{1}{RC} (V_i + V_{ref}) \quad t_d \quad (2)$$

where t_d is the discharge time.

It is seen that providing V_i is greater than 0 the slope resulting from equation (2) is greater than that resulting equation (1).

Since it is a condition that V_{ref} is greater than V_i , these equations show that the sign of the slope changes when the chipper is switched. Thus the integrator output is a sawtooth waveform.

From the equations, it can also be deduced that for a negative input the slopes are reversed: i.e. the positive slope becomes the faster.

The digitised feedback limits the charge in the capacitor C so that a charge balance is obtained between the input voltage and the reference voltage.

From the compensation method the average value of V_D ($V_{Dc} + V_{Dd}$) will be equal to V_i .

$$\text{Consequently: } V_i = \frac{t_c - t_d}{t_c + t_d} \cdot V_{ref} \quad v \quad (3)$$

where $t_c + t_d = t_m$ (measuring time)

Assuming $N =$ total number of pulses f_s during t_m

$n =$ total number of pulses f_s during t_c

then equation (3) can be written as:

$$V_i = \frac{n - (N-n)}{N} \cdot V_{ref}$$

or

$$V_i = \frac{2n - N}{N} \cdot V_{ref} \quad (4)$$

Since an up/down counter is used to count up when $+V_{ref}$ is connected to the integrator, after N sample times the contents of the counter will be $2n - N$.

This counter includes polarity and zero detecting sections and counts the absolute value of $2n - N$ by shifting the counter contents at clock rate through an added circuit that adds one binary up or down according to the state of Q and the polarity.

At the end of the measuring period, the counter content (together with polarity) is serial-shifted out, at clock rate f_0 , at pin 19 in synchronism with the shift pulses at pin 9. The serial data is organised as follows in NBCD code.

	<i>most significant</i> = last bit							<i>least significant bit</i> = first bit									
bit. no.	16	15	14	13	12	11	10	9	8	7	6	5	4	3	2	1	
data	POL	2 ¹	2 ⁰	2 ³	2 ²	2 ¹	2 ⁰	2 ³	2 ²	2 ¹	2 ⁰	2 ³	2 ²	2 ¹	2 ⁰	X	
	10 ³							10 ²							10	1	

In the integrated circuit block HEF 4739 employed in this circuit, $N = 4096$ and $V_{ref} = 2.046$ V.

Figure 24, page 57 shows the internal functions of the block. To obtain a stable display, the contents are divided by two and transferred into a memory, after which the counter is reset.

A new measurement can then start.

Within the circuit block a multiplexer alternately connects each decade of the memory to the decoder driver.

At the same time, a pulse is generated to drive the anode switch of the associated 7-segment "LED". The decoded information is then transferred via the decoder driver to the indicator "LED's", the cathode which are connected in parallel.

Only the indicator with the anode switch closed will light. If the pulse count exceeds 2000, the range counter will assume its next position, after which the next more significant range is switched on and a new measuring cycle is automatically started.

Down-ranging is effected below 0180 pulses, counted during one measuring cycle.

7.1.2.3. Filter inputs to comparator (Fig. 25, page 59)

The comparator is preceded by a fast-acting filter, formed by C127 and FET V128, which follows rapid changes in the input signal, because the lower end of C127 follows the input voltage, by connecting it to the FET source.

7.1.2.4. Start/Stop

The start/stop circuit is formed by the flip-flop integrated circuit D105.

If during data transfer the result detector finds the measured result to be > 1999 or < 180 then the "stop" output goes LOW. The "stop" signal can be used to stop the counting and the timing by applying a logic LOW level to the "start" input by means of a monostable circuit (D105). The measuring action is then delayed until the "start" input has been HIGH for at least 16 clock pulses; this delay period determined by C134 and R157 prevents incorrect measurements during range switching by allowing the input circuits to stabilise.

7.1.2.5. Data hold

With input 27 of D1 switched to -2.5 V (logic zero) the contents of the display are held.

7.1.2.6. Data out

The data outputs on D1 pins 15 to 18 give the state of each digit in NBCD code.

In integrated circuit block D201 the BCD code is converted into a seven-segment code to provide power outputs to drive the indicators directly. The outputs of D201 on pins 9 to 15 are routed via resistors R212 to R218 respectively and are active in the logic zero state.

7.1.2.7. Scan out

The scan outputs (pins 10 to 13) selects one of the four digits in the display.

The scanning order is: 10^3 , 10^2 , 10^1 , 10^0 .

The outputs are normally routed via the invertors of D202 to the bases of the transistors V204 to V207 controlling the numerical display. For display, the inputs to D202 are high to give inverted outputs of logic zero to operate the controlling transistors.

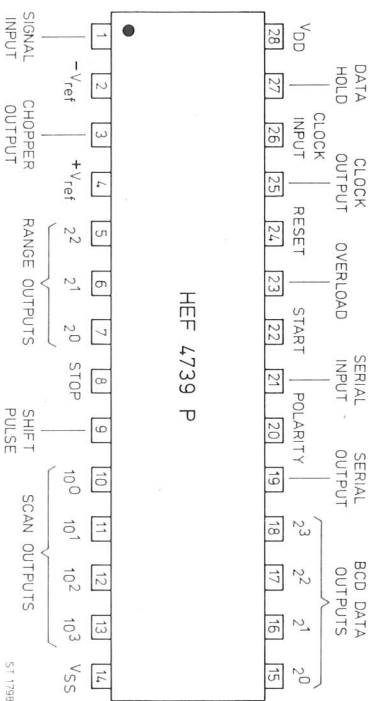

Fig. 23. Pinning of the HEF 4739P

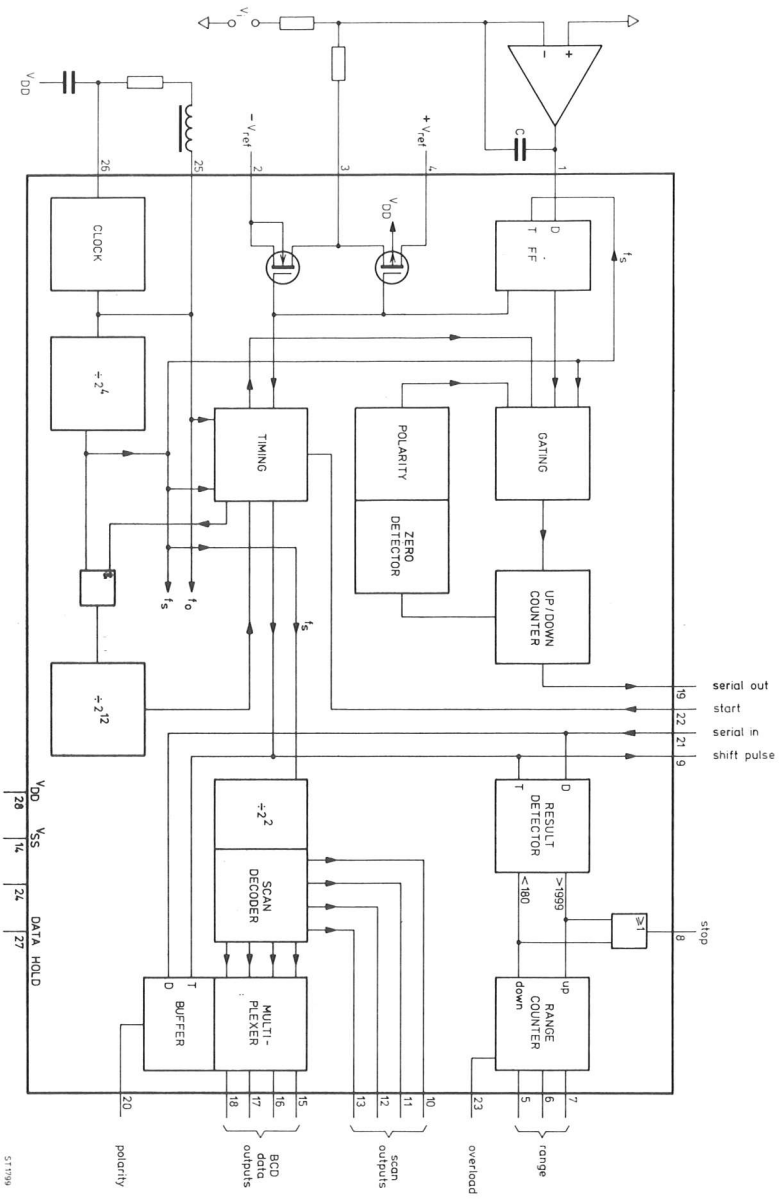

Fig. 24. Block diagram HEF 4739P

7.1.2.8. Overload

In the case of overload, output 23 of D1 (pin 1 of D202) is HIGH. The resulting logic zero output on pin 2 of D202 activates V201, V202, V203 and therefore inputs 3, 9 and 11 are LOW. As these correspond to the 10^3 , 10^1 and 10^0 digits, blanking occurs on display H203, H205 and H206. Consequently, as the maximum display is ≥ 2000 , this blanking leaves a "0" indication in the H204 display to indicate an "0" overload condition.

Drivers D113 provide the necessary output to activate diodes V201 to V203 during overload.

7.1.2.9. Ranging

When the number in the up/down counter is serially shifted out at the clock rate (via pins 19 and 21) into the display buffer, it is also scanned by the result detector.

Depending on whether the BCD number (i.e. $2n - N$) is greater than 1999 or less than 180, the range counter counts up 1 step or down 1 step respectively.

The state of the range counter is available in binary code at pins 5, 6 and 7 of D1.

These outputs for the various ranges, shown in the truth table, are fed to input pins 13, 14 and 15 of logic block D106. Here the signals are routed to gate and inverter circuits to procedure the outputs shown in the table. These are coupled to logic block D107 which provides for range hold. When the RANGE HOLD switch is selected, the logic zero applied to pins 4 and 13 blocks the latches so that the selected range is held. The outputs of D107 feed the range selector -gates that control the range relays K101, K102, K103 and K104.

The state of these relays for the various ranges is also shown in the truth table.

As seen from the truth table (page 59), the corresponding volts, Kilo-ohm and Mega-ohm ranges are all selected by identical logic outputs from D107. However, the relay operation is also defined by the $\underline{\alpha}$, $\underline{\beta}$ and $\underline{\gamma}$ logic states which depend upon the mode selected.

For the volts ranges, the $\underline{\beta}$ line is at logic "1" via R163. For the Kilo-ohm and Mega-ohm ranges, $\underline{\gamma}$ and $\underline{\alpha}$ are at logic "1" respectively. In each case, the remaining two lines are at logic "0".

Decimal point

The four positions of the decimal point are activated by logic zero outputs, a, b, c or d of the four inverter gates D112.

LOGIC 0 OUTPUT	DISPLAY				RANGES
	a	b	c	d	
a	● X	X	X	X	2 V, k Ω , M Ω
b	X	● X	X	X	2 V, k Ω , M Ω
c	X	X	● X	X	20 V, k Ω , M Ω
d	X	X	X	● X	200 V, k Ω
	X	X	X	X	1000 V, 2000 k Ω

Additional gates inhibit the decimal point in the "d" position when switched to M Ω because of the limited number of Mega-ohm ranges.

7.1.3. **Power supply (Fig. 26, page 60)**

The power supply produces stabilised outputs of +9.5 V, +2.9 V and -2.1 V in a balanced network with respect to circuit zero.

In order to supply the 12 V relays K101 to K104, the +9.5 V rail is used with respect to the logic zero -2.1 V (+9.5 V to -2.1 V = 11.6 V).

The logic 5 V is derived from the -2.1 V (logic 0) and +2.9 V supplies; i.e. across resistors R189, V136. The principle of this balanced supply is shown in figure 26.

All supply rails are stabilised by series regulating transistors controlled by zener diodes. Preset resistors R187 provides adjustment for the +2.9 V supply rail.

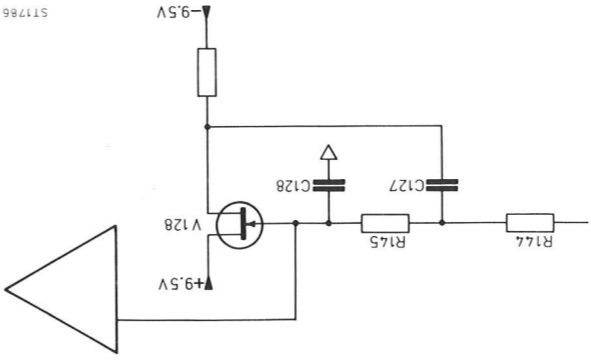

Fig. 25. Fast acting filter

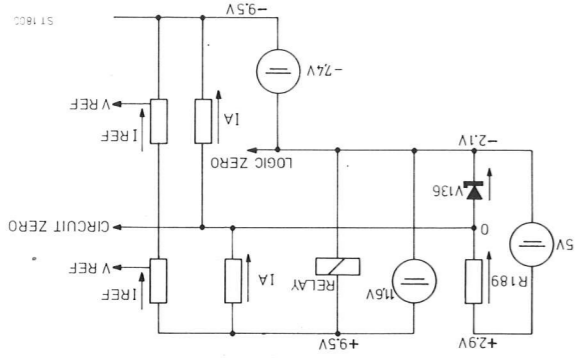

Fig. 26. Power supply principle

RANGE	$\beta = \text{logic "1"}$					$\gamma = \text{logic "1"}$					$\alpha = \text{logic "1"}$				
	0.2 V	2 V	20 V	200 V	1000 V	0.2 k Ω	2 k Ω	20 k Ω	200 k Ω	2000 k Ω	0.2 M Ω	2 M Ω	20 M Ω		
RANGE OUTPUTS HEF 4739	0	0	0	0	0	0	0	0	0	0	0	0	0		
	1	1	1	1	1	1	1	1	1	1	1	1	1		
OUTPUTS D106	0	0	0	0	0	0	0	0	0	0	0	0	0		
	1	1	1	1	1	1	1	1	1	1	1	1	1		
G-INPUT LOGIC "1"	1	0	0	0	0	0	0	0	0	0	0	0	0		
	0	1	1	1	1	1	1	1	1	1	1	1	1		
OUTPUTS D107	1	0	0	0	0	0	0	0	0	0	0	0	0		
	0	1	1	1	1	1	1	1	1	1	1	1	1		
Output D111	1	1	1	1	1	0	0	0	0	0	0	0	0		
Output D109	1	1	1	1	1	1	1	1	1	1	1	1	1		
Output D109	1	1	1	1	1	0	0	0	0	0	0	0	0		
Output D109	1	1	1	1	1	1	1	1	1	1	1	1	1		
RELAYS	K101	X	-	-	-	X	-	-	-	-	X	-	-		
	K102	-	-	-	-	X	X	X	X	X	-	-	-		
	K103	-	-	-	-	X	X	X	X	X	-	-	-		
	K104	X	-	-	-	X	X	X	X	X	-	-	-		
OUTPUTS D112	0	1	1	1	1	0	1	1	1	1	0	1	1		
	1	0	0	0	0	1	0	0	0	0	1	0	0		
	1	1	1	1	1	1	1	1	1	1	1	1	1		
	1	0	0	0	0	1	0	0	0	0	1	0	0		
DECIMAL POINTS	H203	X	-	-	-	X	-	-	-	-	X	-	-		
	H204	-	-	-	-	-	X	X	X	X	-	-	-		
	H205	-	-	-	-	-	-	X	X	X	-	-	-		
	H206	-	-	-	-	-	-	-	-	X	-	-	-		

Truth table PM2523

Relay : X = activated - = not activated
 Decimal point: X = lightened - = blanked

This truth table gives the relation between the range outputs of the HEF 4739, the relays K101 - K104 and the decimal point at the various ranges.

8. ACCESS

The opening of parts, or removal of covers, is likely to expose live conductors.

The instrument should therefore be disconnected from all voltage sources before any opening of parts or removal of covers is started.

During and after dismantling, bear in mind that capacitors in the instrument may be still charged even if it has been separated from all voltage sources.

USE A WELL-FITTING CROSSHEAD SCREW-DRIVER TO DISMANTLE THE INSTRUMENT TO PREVENT THE CROSS-SLOTTED SCREWS FOR DAMAGE.

8.1. DISMANTLING

8.1.1. Top cover

Loosen both screws "A" (Fig. 27, page 63)

Lift the cover at the rear and pull it out of the front panel (Fig. 28, page 63)

To refit the cover push the snaps in the front panel (Fig. 28, page 63)

Keep pushing in the direction of the front panel and smoothly push it down at the rear.

Attention: — First place the bearing handle into bottom cover

— Pay attention that the snaps are proper fitted in the front panel.

8.1.2. Bottom cover

Removing and refitting of the bottom cover can be done in the same way as the top cover.

8.2. FUSES

Make sure that only fuses with the required current rating and of the specified type are used. The use of repaired fuses and the short-circuiting of fuseholders is prohibited.

8.2.1. Fuse F101

Mains fuse F101 is mounted inside on the printed circuit board (Fig. 6, page 38).

The rating of the mains fuse should be: — 220 V +15%: 80 mA slow blow

— 110 V +15%: 160 mA slow blow

8.2.2. Fuse F1

In the resistance circuit fuse F1 will protect A 101B. If the current exceeds 125 mA the fuse will blow.

Required fuse: 125 mA fast glass fuse.

The fuse is mounted in the "VΩ" input terminal (Fig. 9, page 42).

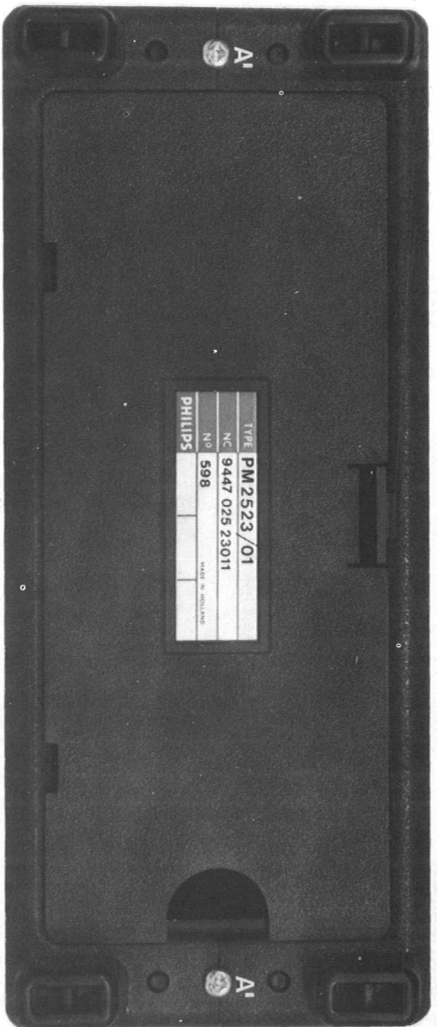

Fig. 27. Rear view

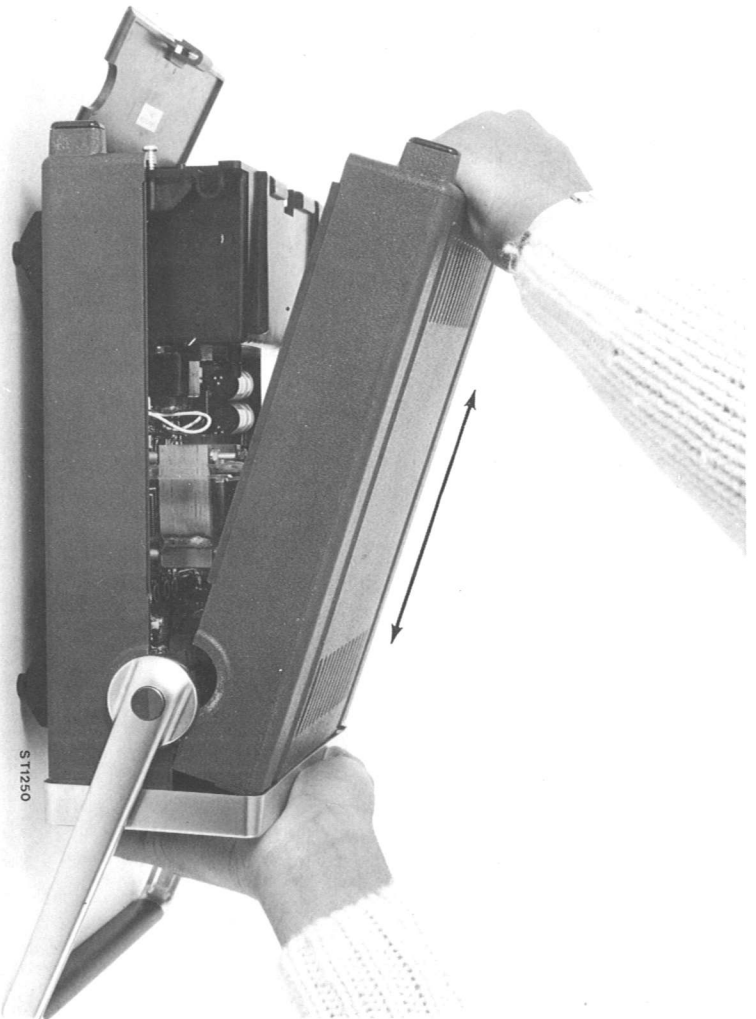

Fig. 28. Removing and refitting top cover

9. TROUBLE SHOOTING

9.1. INTRODUCTION

9.1.1. Hints for repair

If repairs must be performed, the following points should be taken into account to avoid damage of the instrument.

- In case of measurements on a switched-on instrument proceed carefully to avoid short-circuits by means of measuring clips or measuring hooks.
- For soldering use absolutely acid-free soldering tin.
- For all soldering work on the printed circuits board, use a miniature soldering iron (35 W max.) with a tin-cleaner or a vacuum soldering iron.

Remark: *Digital multimeter PM 2523 requires no maintenance because the instrument contains no components which are subject to wear.
However, to ensure reliable and faultless operation, the instrument should not be exposed to moisture, heat, corrosive vapours and excessive dust.*

9.1.2. Procedure

When investigating any fault the following Flow Chart is meant as an aid to locate this fault roughly.
The rough indication in the Flow Chart refers to more detailed circuit parts.

9.2. FLOW CHART

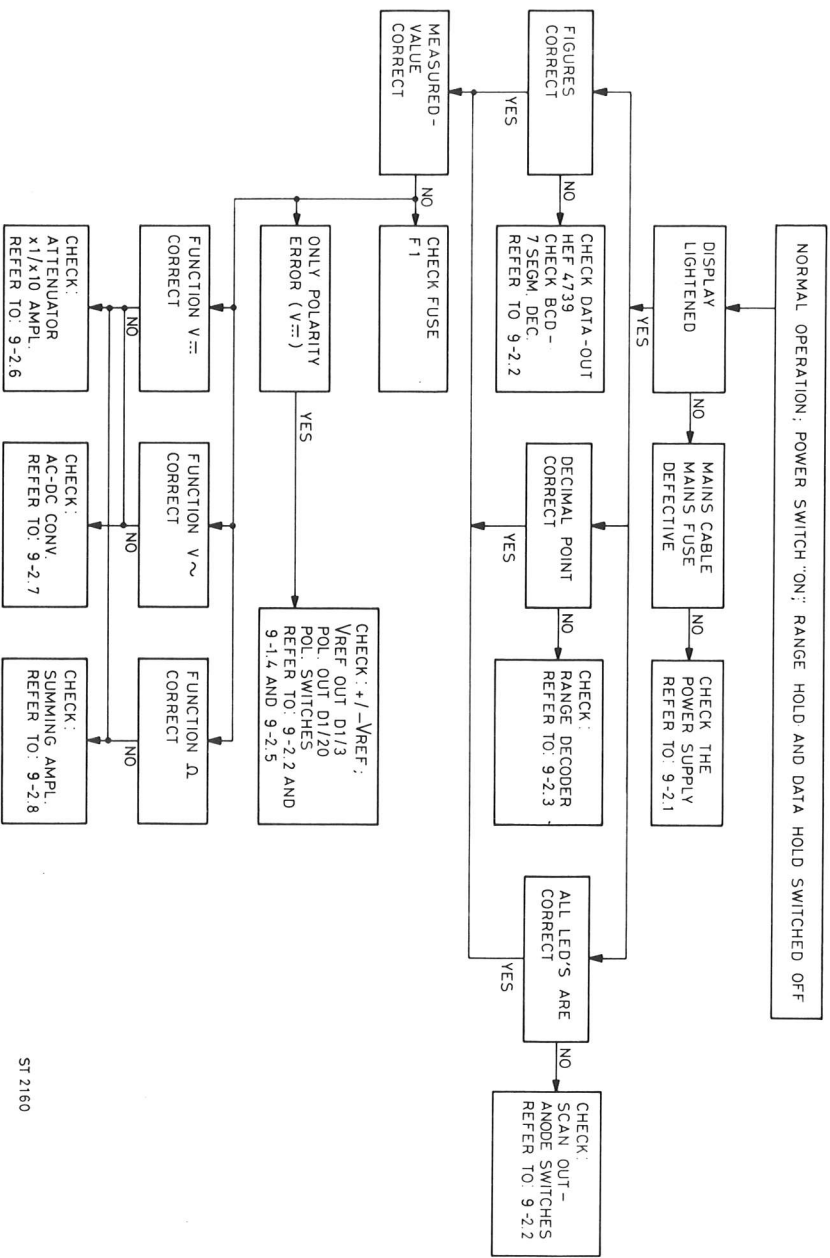

ST 2160

9.2.1. Power supply

Measure the voltages given in the circuit diagram. To disconnect the power supply from the rest of the circuit. Loosen jumpers A-C (see figure 30).

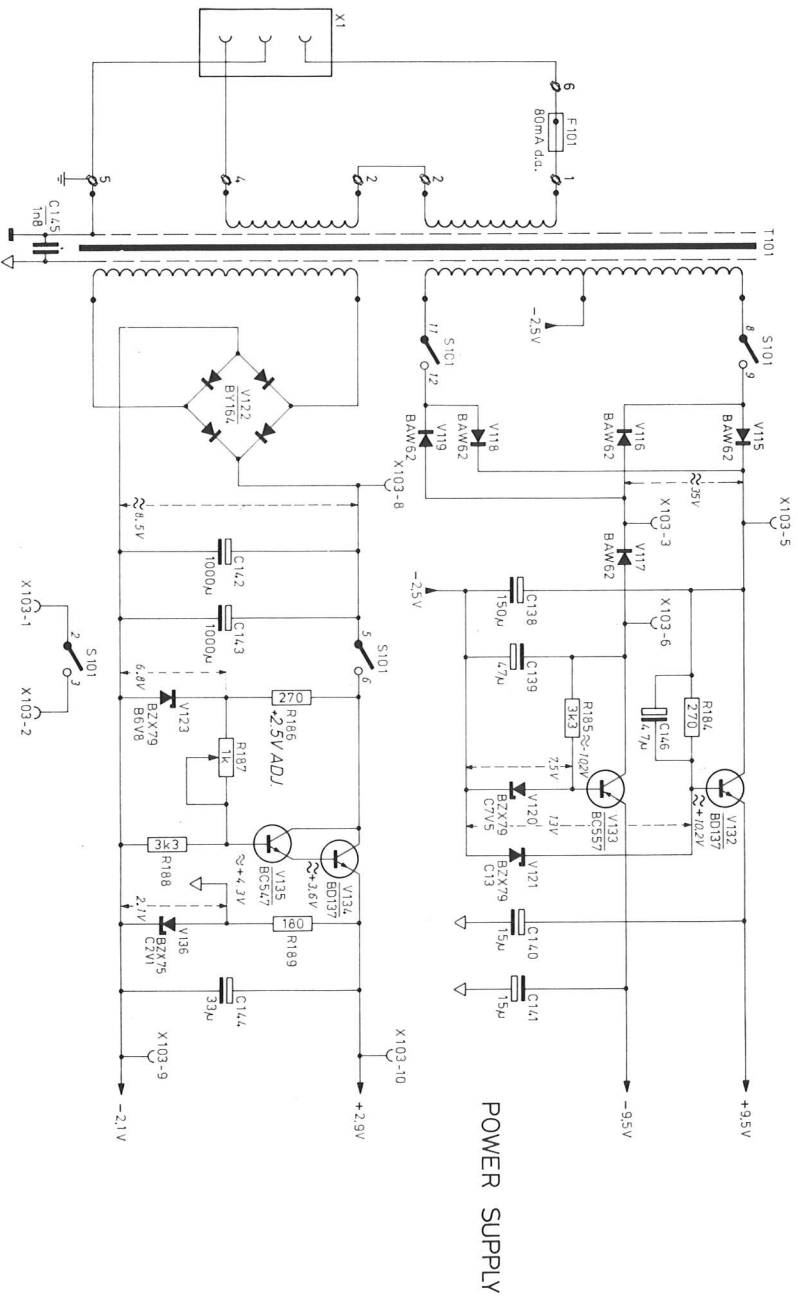

Fig. 29. Power supply

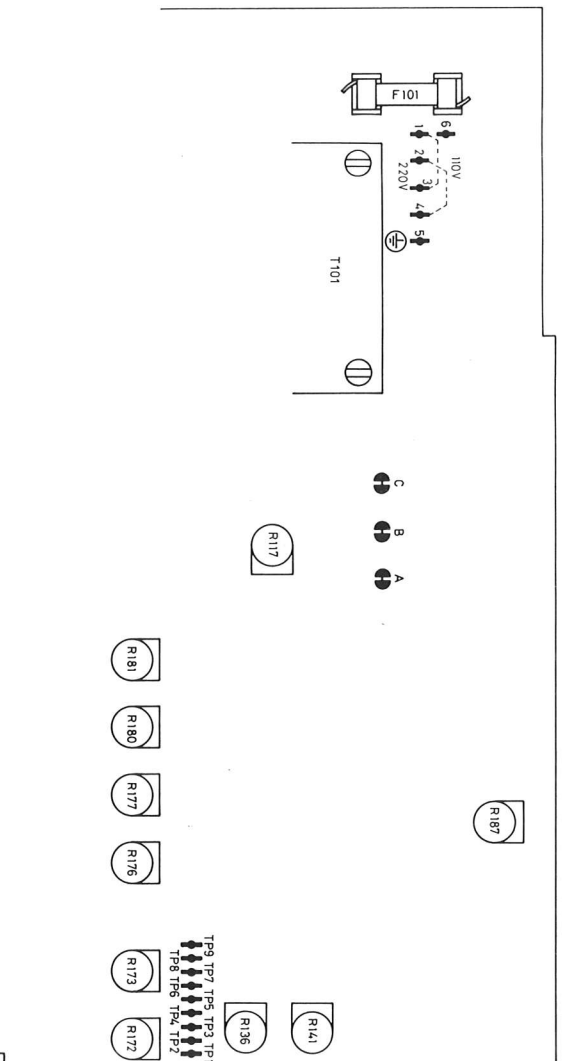

Fig. 30. Location jumpers A, B, C.

9.2.2. BCD → 7 segment decoder/driver

Decimal	DATA OUT HEF 4739				INPUT D201				OUTPUT D201						
	A 15	B 16	C 17	D 18	A 7	B 1	C 2	D 6	a 13	b 12	c 11	d 10	e 9	f 15	g 14
0	0	0	0	0	0	0	0	0	0	0	0	0	0	0	1
1	1	0	0	0	1	0	0	0	1	0	0	1	1	1	1
2	0	1	0	0	0	1	0	0	0	0	1	0	0	1	0
3	1	1	0	0	1	1	0	0	0	0	0	0	1	1	0
4	0	0	1	0	0	0	1	0	1	0	0	1	1	0	0
5	1	0	1	0	1	0	1	0	0	1	0	0	1	0	0
6	0	1	1	0	0	1	1	0	1	1	0	0	0	0	0
7	1	1	1	0	1	1	1	0	0	0	0	1	1	1	1
8	0	0	0	1	0	0	0	1	0	0	0	0	0	0	0
9	1	0	0	1	1	0	0	1	0	0	0	1	1	1	0

0 = SEGMENT is lightened

1 = SEGMENT is blanked

The truth table above gives the relation of the in- and outputs of D201. Using this table we can check printed circuit board (pcb) U2 separately.

Proceed as follows:

Loosen pcb U2 from pcb U1

Supply +5 V at X201/8

Supply 0 V at X201/3

Supply BCD code at X201/4-7 as shown in the table above

Supply logic "1" = +5 V to X202/4-7 via a 10 kΩ resistance alternately

See truth table below

} Locate on pcb U2

LED will light up depending on the BCD code and scan input X201/4-7.

To check anode switches: supply at X202/4-7 logic "0" = 0 V, all LED's are blanked.

To check polarity switches: supply at X202/1 logic "0" = 0 V, -lights +blanked
supply at X202/1 logic "1" = +5 V, +lights -blanked

To check overload: supply at X202/4-7 logic "1" = +5 V

supply at X202/3 logic "1" = +5 V via 10 kΩ resistance
all LED's are blanked except H204.

X202	4	5	6	7	H203	H204	H205	H206
					X	-	-	-
	1	0	0	0	X	-	-	-
	0	1	0	0	-	X	-	-
	0	0	1	0	-	-	X	-
	0	0	0	1	-	-	-	X

X = lightened

9.2.4. + and - reference

Measure the voltages of the + and - reference as shown in the circuit diagram, below.

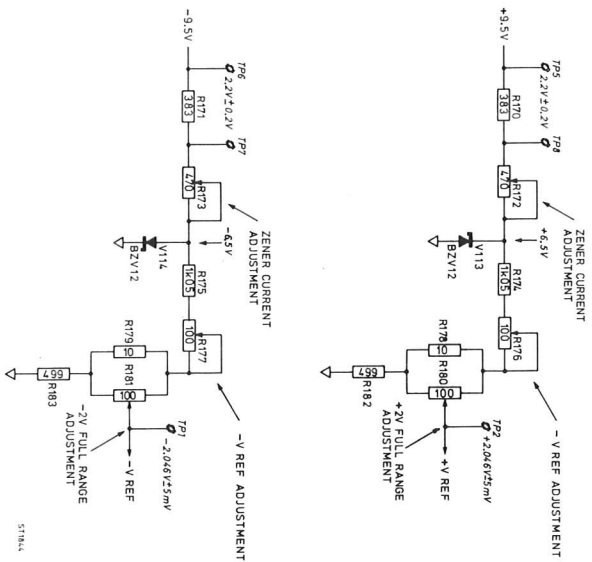

Fig. 31. + and - reference

9.2.5. Analog-Digital convertor

- Disconnect R144 from V_i / 2
- Supply +1 V and -1 V alternately at R144
- Measure the wave forms as shown in figure 32
- Signals not present 1. replace A103
2. replace D1

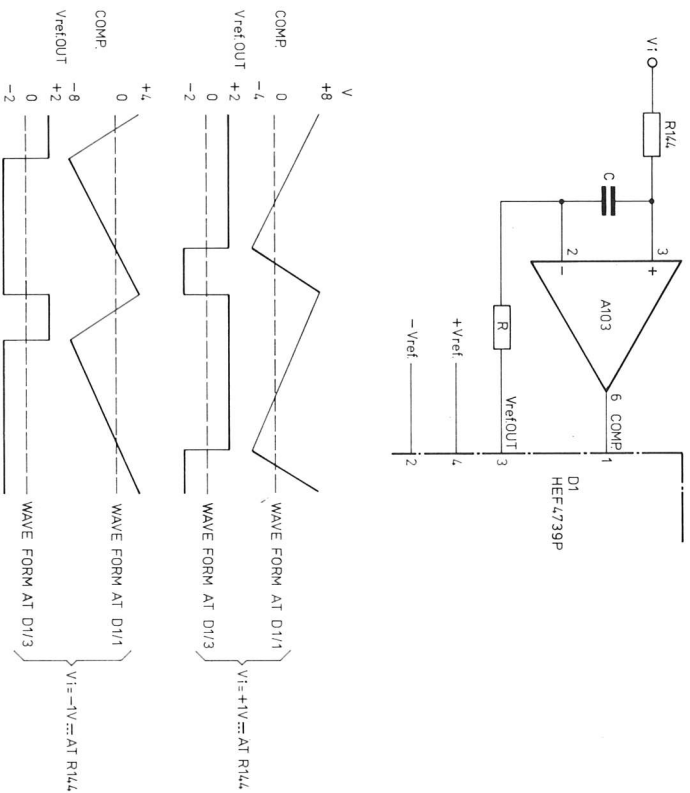

Fig. 32. Analog-Digital convertor

9.2.6. $x1/x10$ Amplifier

At input V_{S2} : 0.1 V, 1 V, 10 V, 100 V, 1000 V \dots .
 Amplifier output A101/5, in all ranges 1 V see figure 33 and table below.

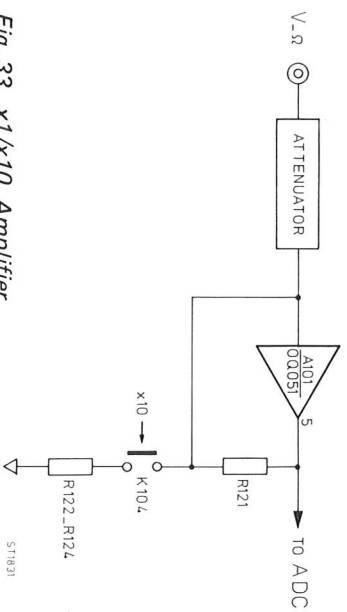

Fig. 33. $x1/x10$ Amplifier

INPUT	RANGE	ATTENUATION	AMPLIFICATION	AMP. OUT A101/5
0.1 V	0.2 V	1 x	x10	1 V
1 V	2 V	1 x	x1	1 V
10 V	20 V	100 x	x10	1 V
100 V	200 V	100 x	x1	1 V
1000 V	1000 V	10000 x	x10	1 V

9.2.7. AC-DC convertor

Supply at input V_{S2} an AC voltage V_{\sim} switch pressed.

- Measure with oscillograph at C121 (see Fig. 34A)
- Oscillograph shows Fig. 34B
- Measure with oscillograph switch $V_{\sim}/3$
- Oscillograph shows Fig. 34C.

If not correct: 1. Check diodes V107 and V106 to ADC
 2. Replace A102

9.2.8. Summing Amplifier

Input between V_{S2} and 0 a resistance of 10 k Ω
 Voltage over 10 k Ω = 1 V

If not correct proceed as follows:

- Measure output A101a/6 = 1 V
- Measure output A101b/10 = 1 V + 1.025 V = 2.025 V.

If not correct: 1. Replace A101
 2. Replace A101

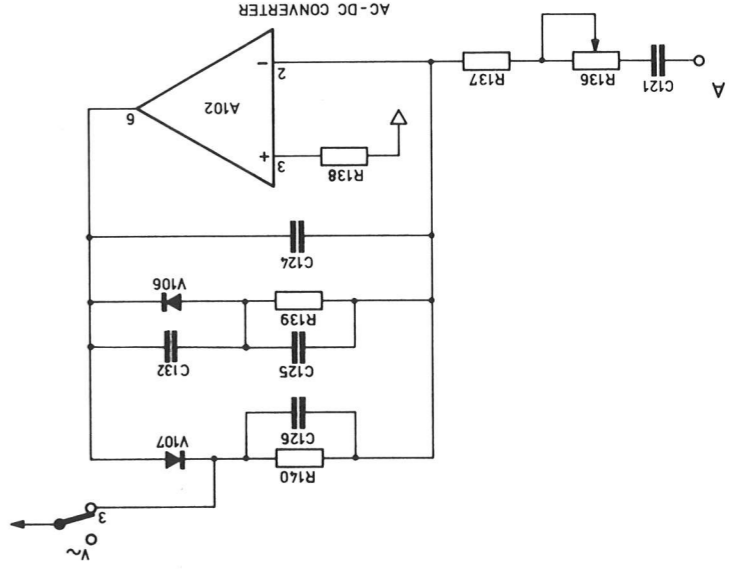
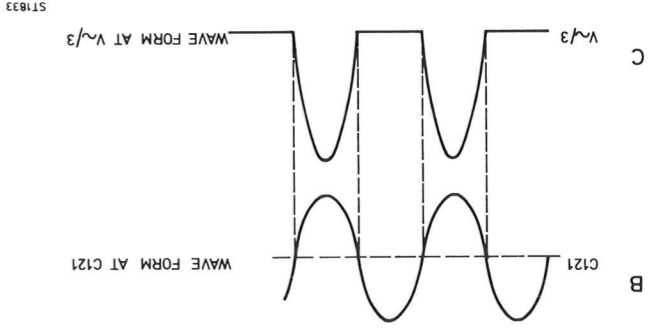

Fig. 34. AC - DC converter



10. CHECKING AND ADJUSTING

The tolerances stated in this section correspond to the factory, data and only apply to a recently adjusted instrument.
When individual components, especially semi-conductors are replaced, the relevant section should be completely readjusted.

10.1. CALIBRATION AND ADJUSTING PROCEDURE

The table gives together with figure 35 all adjustments and calibrations only to be carried out if one or more electrical components have been replaced.
All adjustments should be carried out with the pushbuttons "RANGE HOLD" and "DATA HOLD" not depressed.

No.	ADJUSTMENTS	ADJUSTING ELEMENTS	PREPARATIONS	INPUT SIGNALS	ADJUSTING DATA	MEASURING POINTS
1	+2.5 V Supply	R187	Push V	-	+2.9 V ± 0.25 V	Jumper "A" TP9*
2	"Zero" Coarse	R117	Push V	Shortcircuited	0.000 V ± 0.5 mV	TP4-TP9*
3	R1 "0" midrange					
3	"0" Fine	R1	Push V	Shortcircuited	0.000 V	TP4-TP9*
4	+Vref - Iz	R173	Push V	Shortcircuited	+2.2 V ± 0.2 V	TP5-TP8*
5	-Vref - Iz	R172	Push V	Shortcircuited	-2.2 V ± 0.2 V	TP6-TP7*
6	+Vref	R176	Push V	Shortcircuited	+2.046 V ± 0.5 mV	TP2-TP9*
7	-Vref	R177	Push V	Shortcircuited	-2.046 V ± 0.5 mV	TP1-TP9*
8	Zero ADC	R149	Push V	Shortcircuited	.0000	Display
9	+2 V	R180	Push V	+1.900 V ± 1 mV	+1.900 ± 1 digit	Display
10	-2 V	R181	Push V	-1.900 V ± 1 mV	-1.900 ± 1 digit	Display
11	Check adj. "8". If necessary readjust. In case of readjusting, repeat adjustments 9 and 10.					
12	10x amplifier	R124	Push V	+1.900 V ± 0.2 mV	+1.900 ± 2 digits	Display
13	20 V	R102	Push V	+19.00 V ± 10 mV	+19.00 ± 1 digit	Display
14	Zero AC/DC	R141	Push V	Shortcircuited	.0000	Display
15	2 \sim 1 kHz	R136	Push V	1.900 V ± 2 mV 1 kHz	1.900 ± 3 digits	Display
16	20 V \sim 10 kHz	C106	Push V	19.00 V ± 20 mV 10 kHz	19.00 ± 3 digits	Display
17	20 k Ω	R125	Push k Ω	17 k Ω $\pm 10 \Omega$	17.00 ± 2 digits	Display

*With external voltmeter e.g. PM 2527.

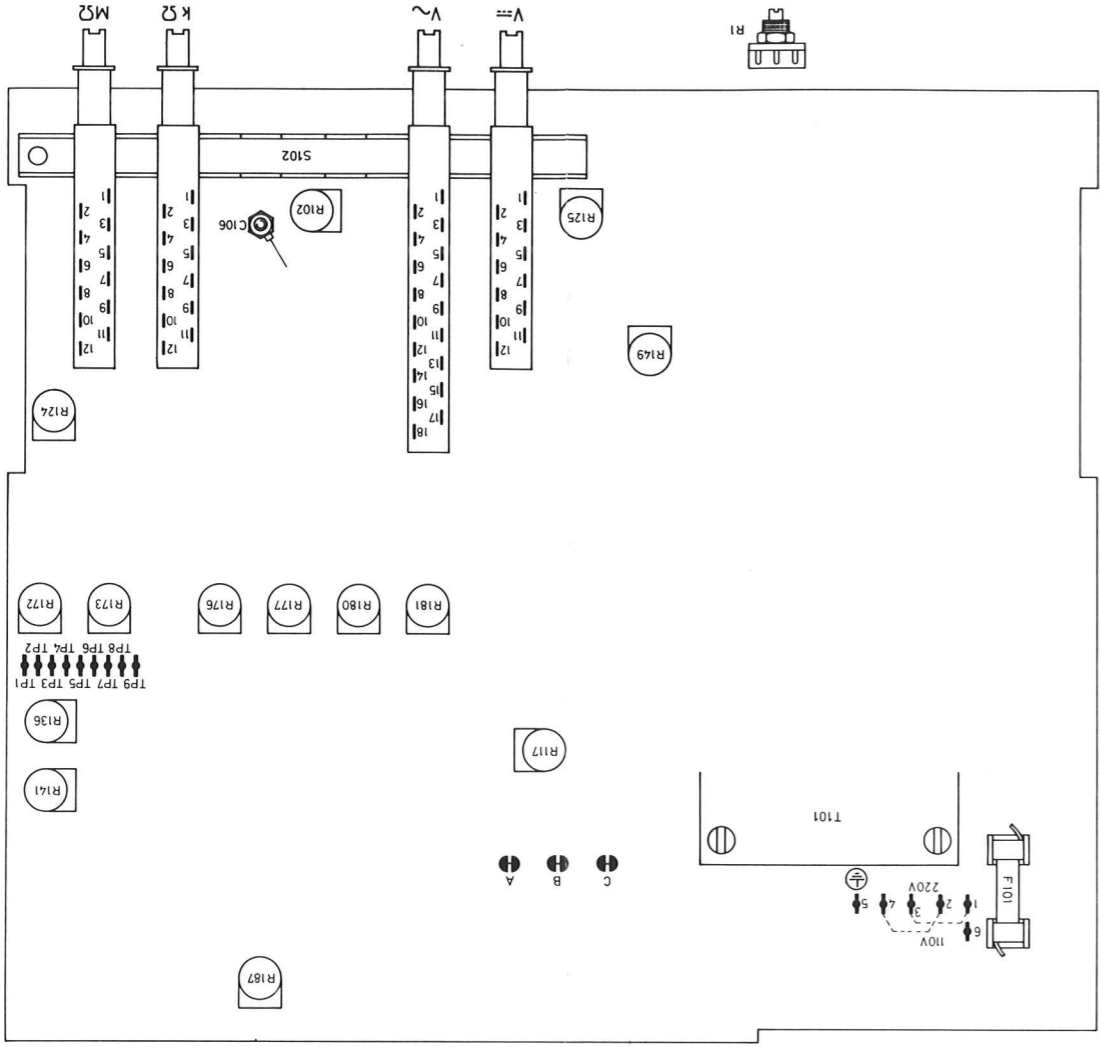

Fig. 35. Location of adjusting elements

11. LIST OF PARTS

11.1. MECHANICAL

<i>Item</i>	<i>Fig.</i>	<i>Ordering number</i>	<i>Type/description</i>
1	—	5322 447 94216	Front assy
2	36	5322 498 54055	Handle assy
3	36	5322 256 34048	Fuse holder
4	36	5322 447 94192	Cap
5	37	5322 447 94193	Container
6	37	5322 447 94194	Cover
7	36	5322 456 14049	Textplate
8	37	5322 462 44181	Rear foot
9	36	5322 466 85335	Front rim
10	37	5322 462 44179	Foot
11	37	4822 462 70497	Plug for foot
12	36	5322 450 64056	Window
13	6	5322 405 94087	Bracket
14	36	5322 492 64535	Leave spring for fuse
15	36	5322 492 54246	Spring for fuse
16	—	5322 447 94195	Indicator housing
17	36	5322 466 85336	Extension spindle
18	36	5322 414 14011	Push button switch knob
19	—	5322 466 94461	Plate for "0" potentiometer
20	6	5322 255 44068	Heat sink for V134
21	6	5322 255 44165	IC holder 16P for A101
22	—	5322 255 44166	IC holder 28P for D104

11.2. MISCELLANEOUS

<i>Item</i>	<i>Fig.</i>	<i>Ordering number</i>	<i>Type/description</i>
X1	37	5322 265 30066	Mains connector
X101	—	5322 267 54038	Bus connector
X102	—	5322 265 54006	Bus connector
X103	37	5322 267 64027	Bus connector
K101	—	5322 280 24083	Reed contact
K102	—	5322 280 24047	Reed relay
K103	—	5322 280 24047	Reed relay
K104	—	5322 280 24047	Reed relay
L101	—	5322 281 60125	Coil
L102	—	5322 158 10304	Microchoke
S101	36	5322 276 14242	Push button switch
S102	36	5322 276 44045	Push button switch
S1	36	5322 276 24035	Push button switch
T101	6	5322 146 24148	Transformer
F101	6	4822 253 20007	Fuse 125 mA
F101		4822 253 30005	Fuse 125 mA
H201-202		4822 134 40167	Indication lamp 5 V-60 mA
X201	40	5322 264 54017	Pin connector
X202	40	5322 264 54017	Pin connector
H203-206		5322 130 34524	Display CQY81
		5322 321 10071	Mains cable
		5322 264 24013	Test pin red
		5322 264 24014	Test pin black

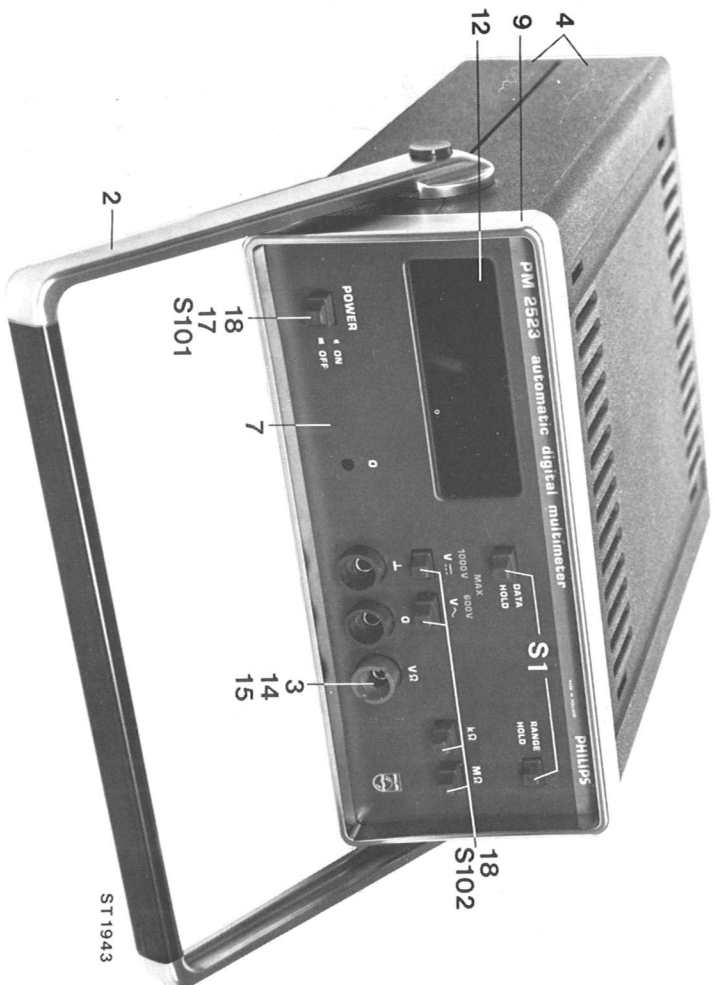

Fig. 36. Front view with item numbers

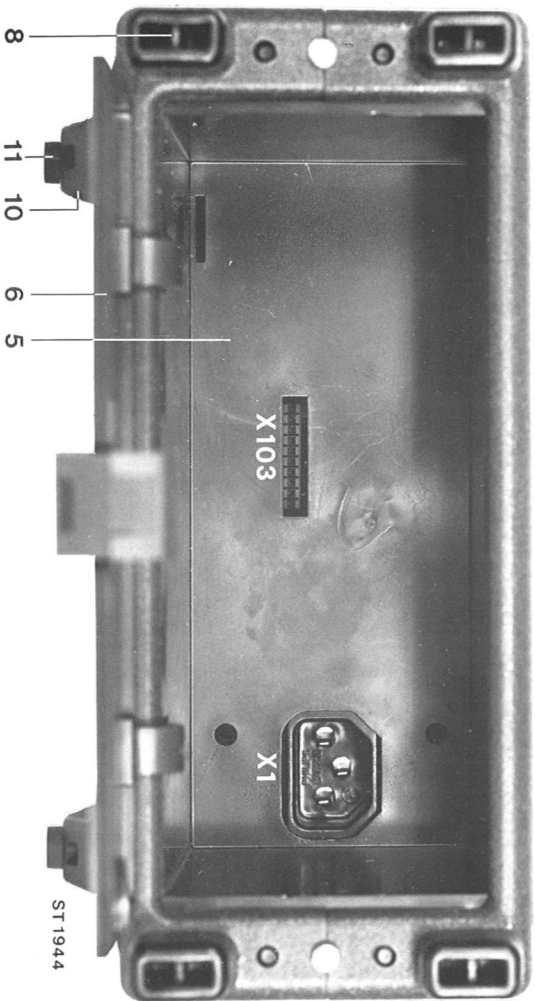

Fig. 37. Rear view with item numbers

11.3. ELECTRICAL

11.3.1. Resistors

<i>Item</i>	<i>Ordering number</i>	<i>Ohm</i>	<i>Tol (%)</i>	<i>Type</i>	<i>Remarks</i>
R101	5322 116 64036	9.76 M	1	VR37	Metal oxide
R102	4822 100 10088	220 k	20	0.1 W	Trimming potm
R103	5322 116 54945	98.8 k	0.1	MR24C	Metal film
R104	5322 116 50676	196		MR25	Metal film
R105	5322 116 54155	1 k	0.1	MR24C	Metal film
R107	5322 116 54696	100 k	1	MR25	Metal film
R108	5322 116 54188	1 M	1	MR30	Metal film
R109	5322 116 54188	1 M	1	MR30	Metal film
R110	5322 116 54642	20 k	1	MR25	Metal film
R111	5322 116 54479	127	1	MR25	Metal film
R112	4822 112 21076	68	5	4.2 W	Wire-wound
R114	5322 116 50577	215 k	1	MR30	Metal film
R117	4822 100 10075	100	20	0.1 W	Trimming potm
R121	5322 116 50748	10 k	0.1	MR24C	Metal film
R122	5322 116 54944	1.09 k	0.1	MR24C	Metal film
R123	5322 116 51052	42.2	1	MR25	Metal film
R124	4822 100 10075	100	20	0.1 W	Trimming potm
R125	4822 100 10035	10 k	20	0.1 W	Trimming potm
R126	5322 116 54696	100 k	1	MR25	Metal film
R130	5322 116 54696	100 k	1	MR25	Metal film
R131	5322 116 50559	27.4 k	1	MR25	Metal film
R136	4822 100 10019	220	20	0.1 W	Trimming potm
R137	5322 116 50631	4.53 k	1	MR25	Metal film
R139	5322 116 54619	10 k	1	MR25	Metal film
R140	5322 116 54619	10 k	1	MR25	Metal film
R141	5322 101 14099	4.7 M	20	0.1 W	Trimming potm
R144	5322 116 54696	100 k	1	MR25	Metal film
R149	4822 100 10019	220	20	0.1 W	Trimming potm
R159	5322 116 50731	10 k	1	MR25	Metal film
R170	5322 116 54518	383	1	MR25	Metal film
R171	5322 116 54518	383	1	MR25	Metal film
R172	4822 100 10038	470	20	0.1 W	Trimming potm
R173	4822 100 10038	470	20	0.1 W	Trimming potm
R174	5322 116 54552	1.05 k	1	MR25	Metal film
R175	5322 116 54552	1.05 k	1	MR25	Metal film
R176	4822 100 10075	100	20	0.1 W	Trimming potm
R177	4822 100 10075	100	20	0.1 W	Trimming potm
R178	5322 116 50452	10	1	MR25	Metal film
R179	5322 116 50452	10	1	MR25	Metal film
R180	4822 100 10075	100	20	0.1 W	Trimming potm
R181	4822 100 10075	100	20	0.1 W	Trimming potm
R182	5322 116 54524	499	1	MR25	Metal film
R183	5322 116 54524	499	1	MR25	Metal film
R187	4822 100 10037	1 k	20	0.1 W	Trimming potm
R190	5322 116 54557	121 k	1	MR25	Metal film

11.3.2. Capacitors

Item	Ordering number	Farad	Tol(%)	Volts	Remarks
C101	4822 121 40342	47 n	10	630	Polyester foil
C102	4822 122 31205	47 p	2	500	Ceramic plate
C103	4822 122 31205	47 p	2	500	Ceramic plate
C104	4822 122 31206	56 p	2	500	Ceramic plate
C105	4822 122 31206	56 p	2	500	Ceramic plate
C106	5322 125 64001	18 p	2	500	Trimmer
C107	5322 121 54148	5.1 n	1	63	Polystyrene foil
C108	4822 122 31081	100 p	2	100	Ceramic
C109	4822 121 40232	0.22 μ	10	100	Polyester foil
C110	4822 121 40257	0.33 μ	10	100	Polyester foil
C111	4822 121 40411	33 n	10	630	Ceramic
C112	4822 121 40232	0.22 μ	10	100	Polyester foil
C113	4822 121 40279	68 n	10	630	Polyester foil
C114	5322 121 40301	15 n	10	250	Polyester foil
C116	4822 122 30103	22 n	- 20 + 80	63	Ceramic plate
C117	4822 122 31165	330 p1	0	100	Ceramic plate
C115	4822 121 41134	10 n	10	630	Polyester foil
C118	4822 122 31177	470 p	10	100	Ceramic plate
C119	4822 122 31221	1.5 n	10	100	Ceramic plate
C120	4822 122 30103	22 n	-20+100	40	Ceramic plate
C121	4822 124 20467	15 μ		16	Electrolytic
C122	4822 122 31168	270 p	10	100	Ceramic plate
C123	4822 122 31085	150 p	2	100	Ceramic plate
C124	4822 122 31045	4.7 p	0.25p	100	Ceramic plate
C125	4822 122 31047	5.6 p	0.25p	100	Ceramic plate
C126	4822 122 31047	5.6 p	0.25p	100	Ceramic plate
C127	4822 121 40438	0.47 μ	10	100	Polyester foil
C128	5322 121 40323	0.1 μ	10	100	Polyester foil
C129	4822 121 40239	47 n	10	100	Polyester foil
C130	4822 122 30103	22 n	-20+100	40	Ceramic plate
C131	4822 122 31043	3.9 p	0.25p	100	Ceramic
C132	4822 122 31043	3.9 p	0.25p	100	Ceramic
C133	4822 122 31173	220 p	10	100	Ceramic plate
C134	4822 124 20453	68 μ		6.3	Electrolytic
C135	4822 124 20474	3.3 μ		25	Electrolytic
C136	4822 124 20474	3.3 μ		25	Electrolytic
C137	4822 124 20474	3.3 μ		25	Electrolytic
C138	4822 124 20481	150 μ		25	Electrolytic
C139	5322 124 20371	47 μ		25	Electrolytic
C140	4822 124 20467	15 μ		16	Electrolytic
C141	4822 124 20467	15 μ		16	Electrolytic
C142	4822 124 20524	1000 μ		16	Electrolytic
C143	4822 124 20524	1000 μ		16	Electrolytic
C144	4822 124 20452	33 μ		6.3	Electrolytic
C146	4822 124 20466	4.7 μ		16	Electrolytic
C145	4822 122 31043	3.9 p	0.25p	100	Ceramic

11.3.3. Semi-conductors

<i>Item</i>	<i>Ordering number</i>	<i>Type/description</i>
Diodes		
V101	5322 130 34299	BZX70/C10 Zener
V102	5322 130 34299	BZX70/C10 Zener
V103 - 104	5322 130 34189	BAV20 Diode
V105 - 112	5322 130 30613	BAW62 Diode
V113	5322 130 34269	BZV12 Zener
V114	5322 130 34269	BZV12 Zener
V115 - 119	5322 130 30613	BAW62 Diode
V120	5322 130 30666	BZX79/C7V5 Zener
V121	5322 130 30771	BZX79/C13 Zener
V122	5322 130 30414	BY164 Bridge rectifier
V123	5322 130 34278	BZX79/B6V8 Zener
V124	5322 130 30191	OA95 Diode
V201	5322 130 30613	BAW62 Diode
V202	5322 130 30613	BAW62 Diode
V203	5322 130 30613	BAW62 Diode
V136	5322 130 34049	BZX75/C2V1 Stabistor
Transistors		
V125	5322 130 44528	ON527
V126	5322 130 44257	BC547
V127	5322 130 44256	BC557
V128	5322 130 40408	BFW11
V129	5322 130 44404	BFQ13
V132	5322 130 40664	BD137
V133	5322 130 44256	BC557
V134	5322 130 40664	BD137
V135	5322 130 44257	BC547
V204	5322 130 44104	BC328
V205	5322 130 44104	BC328
V206	5322 130 44104	BC328
V207	5322 130 44104	BC328
V208	5322 130 44256	BC557
V209	5322 130 44256	BC557
Integrated circuits		
A101	5322 209 84444	OD051
A102	5322 209 84679	LM301AN
A103	5322 209 84598	LM741CN
D1	5322 209 85327	HEF4739p
D105	5322 209 84231	SN74122N-00
D106	5322 209 80142	SN74422AN-00
D107	5322 209 80059	SN7475N-00
D108	5322 209 84227	SN7402N-00
D109	5322 209 84286	SN7451N-00
D110	5322 209 84528	SN7400N-00
D111	5322 209 84181	SN7454N-00
D112	5322 209 84073	SN7406N-00
D113	5322 209 84761	SN7407N-00
D201	5322 209 84681	SN7447N-00
D202	5322 209 80148	SN7404N-00

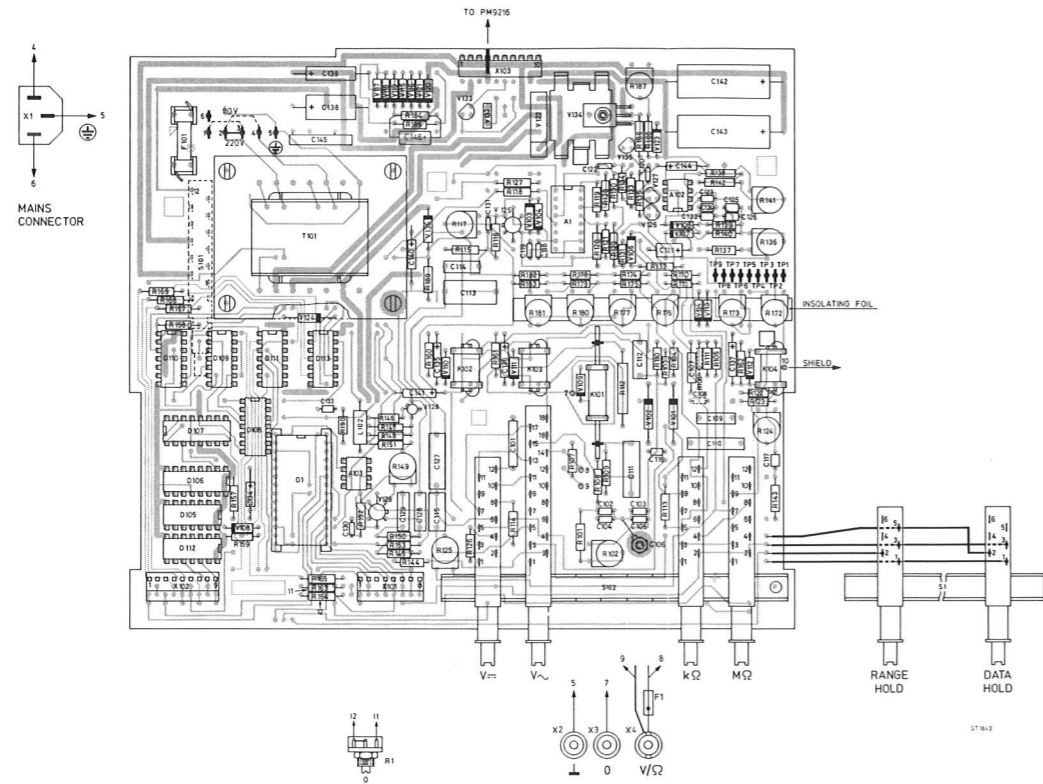

Fig. 38. P.c.b. U1 (component side)

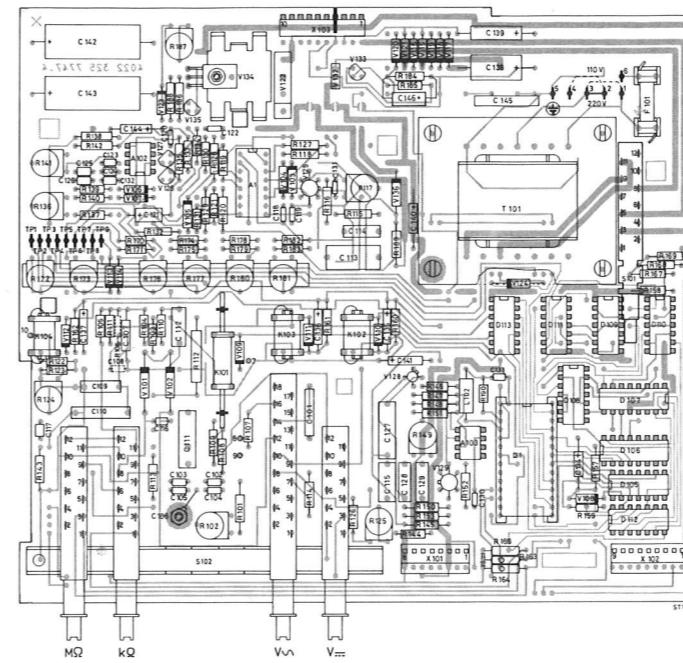

Fig. 39. P.c.b. U1 (conductor side)

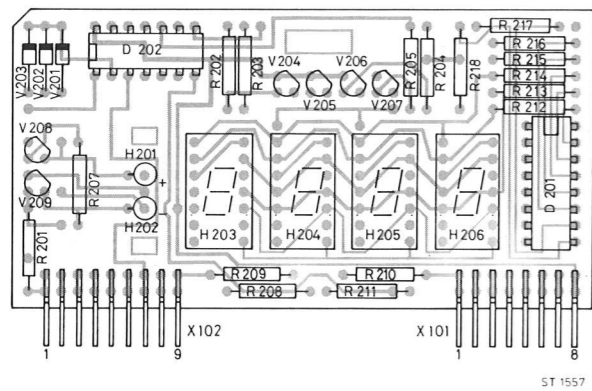

Fig. 40. P.c.b. U2 (component side)

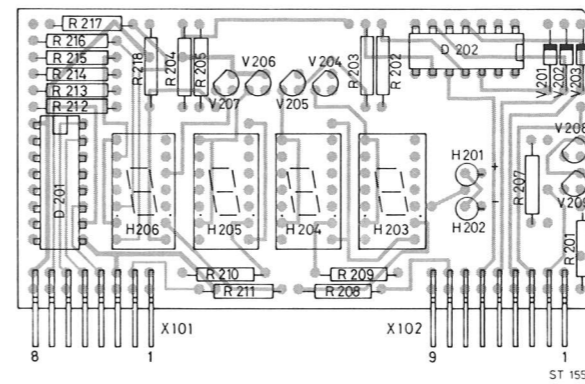

Fig. 41. P.c.b. U2 (conductor side)

**CODING SYSTEM OF FAILURE REPORTING FOR QUALITY
ASSESSMENT OF T & M INSTRUMENTS**
(excl. potentiometric recorders)

The information contents of the coded failure description is necessary for our computerized processing of quality data.

Since the reporting of repair and maintenance routines must be complete and exact, we give you an example of a correctly filled-out PHILIPS SERVICE Job sheet:

① Country ② Day Month Year ③ Typenumber ④ Factory/Serial no.

CODED FAILURE DESCRIPTION

⑤

Nature of call	Location	Component/sequence no.	Category
Installation		T S 0 6 0 7	5
Pre sale repair		R 0 0 6 3 1	2
Preventive maintenance	0 0 2 1	9 9 0 0 0 1	4
Corrective maintenance			
Other			

⑦ Job completed

⑧ Working time Hrs

Detailed description of the information to be entered in the various boxes:

① Country: = Switzerland

② Day Month Year = 15 April 1975

③ Type number/Version = Oscilloscope PM 3260, version 02 (in later oscilloscopes this number is placed in front of the serial no)

④ Factory/Serial number = DO 783 These data are mentioned on the type plate of the instrument

⑤ Nature of call: Enter a cross in the relevant box

⑥ Coded failure description

Location

These four boxes are used to isolate the problem area.

Write the code of the part in which the fault occurs, e.g. unit no or mechanical item no

of this part (refer to 'PARTS LISTS' in the manual).

Example: 0001 for Unit 1

000A for Unit A

0075 for item 75

If units are not numbered, do not fill in the four boxes; see Example Job sheet.

Component/sequence no.

These six boxes are intended to pinpoint the faulty component.

A. Enter the component designation as used in the circuit diagram. If the designation is alpha-numeric, the letters must be written (starting from the left) in the two left-hand boxes and the figures must be written (in such a way that the last digit occupies the right-most box) in the four right-hand boxes.

B. Parts not identified in the circuit diagram:

- 990000 Unknown/Not applicable
- 990001 Cabinet or rack (text plate, emblem, grip, rail, graticule, etc.)
- 990002 Knob (incl: dial knob, cap, etc.)
- 990003 Probe (only if attached to instrument)
- 990004 Leads and associated plugs
- 990005 Holder (valve, transistor, fuse, board, etc.)
- 990006 Complete unit (p.w. board, h.t. unit, etc.)
- 990007 Accessory (only those without type number)
- 990008 Documentation (manual, supplement, etc.)
- 990009 Foreign object
- 990099 Miscellaneous

Category

- 0 Unknown, not applicable (fault not present, intermittent or disappeared)
- 1 Software error
- 2 Readjustment
- 3 Electrical repair (wiring, solder joint, etc.)
- 4 Mechanical repair (polishing, filing, remachining, etc.)
- 5 Replacement (of transistor, resistor, etc.)
- 6 Cleaning and/or lubrication
- 7 Operator error
- 8 Missing items (on pre-sale test)
- 9 Environmental requirements are not met

⑦ Job completed: Enter a cross when the job has been completed.

⑧ Working time: Enter the total number of working hours spent in connection with the job (excluding travelling, waiting time, etc.), using the last box for tenths of hours.

= 1,2 working hours (1 h 12 min.)

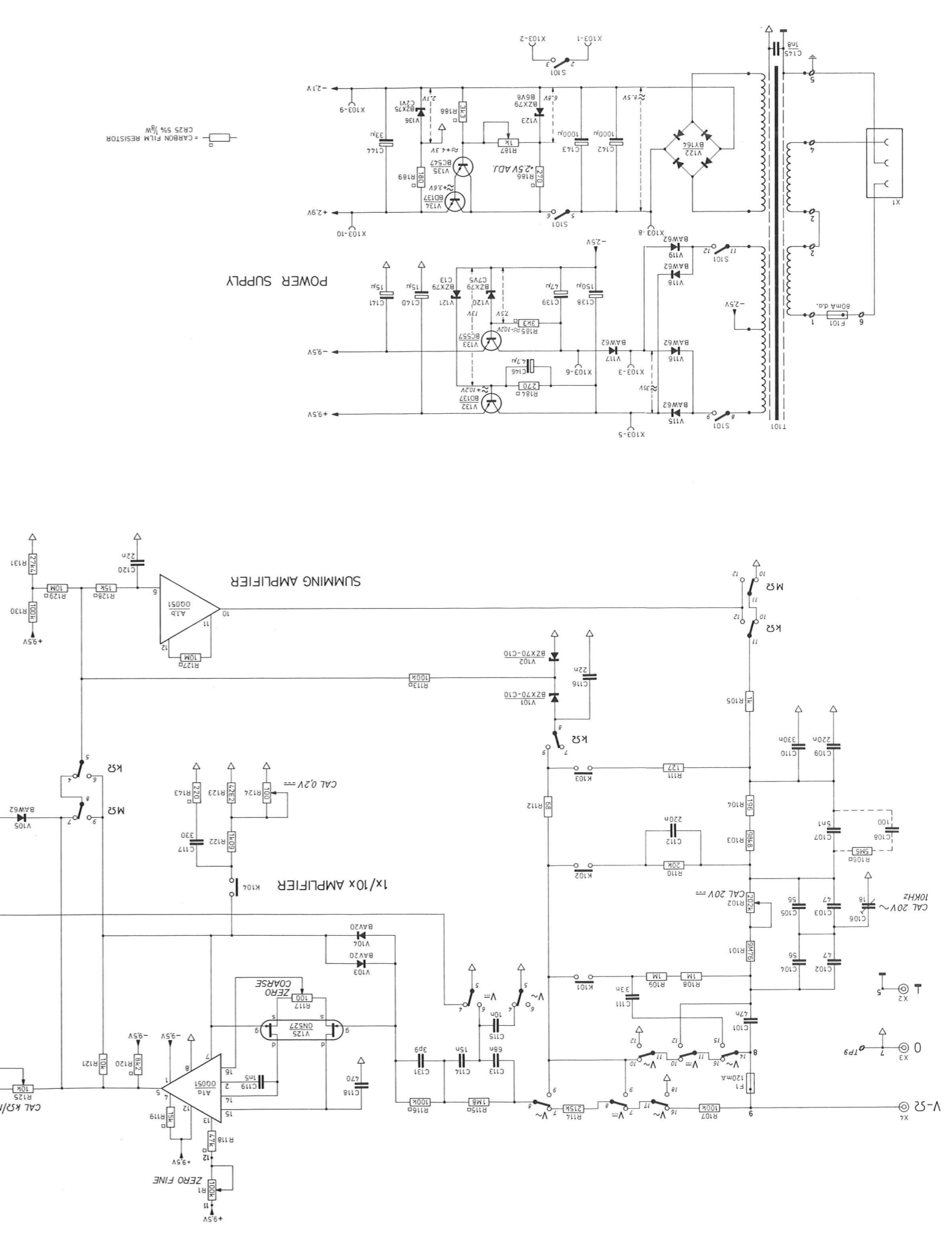
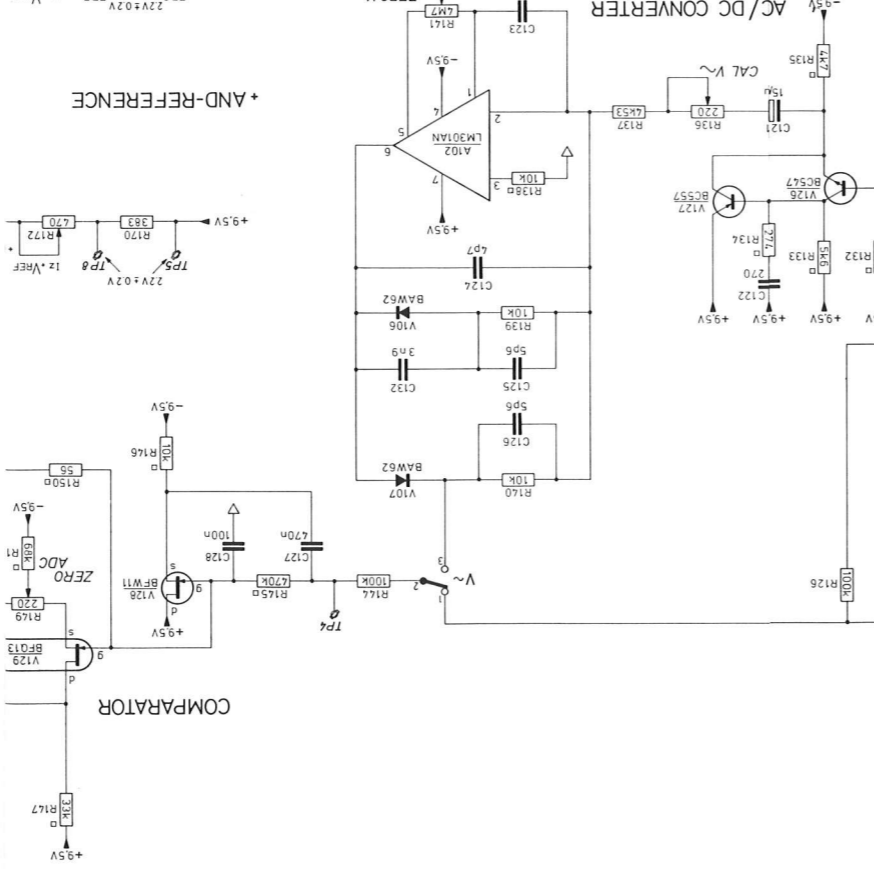
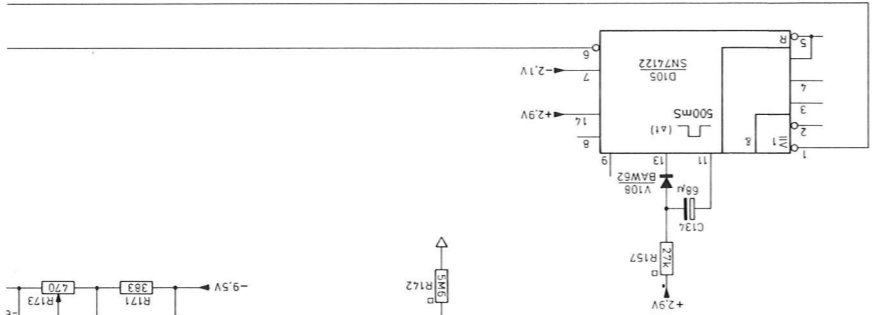
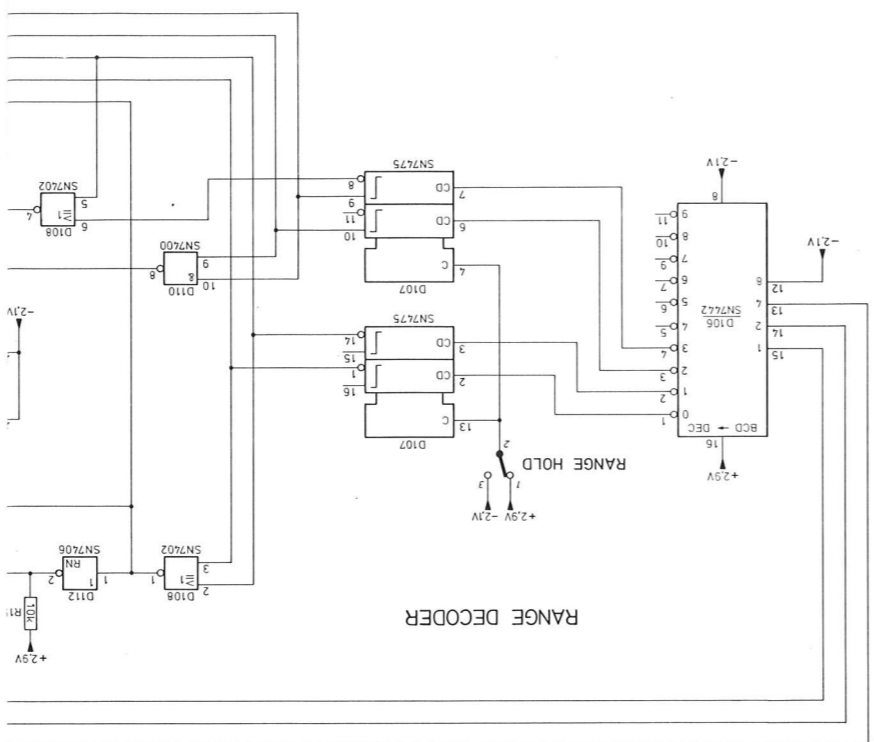
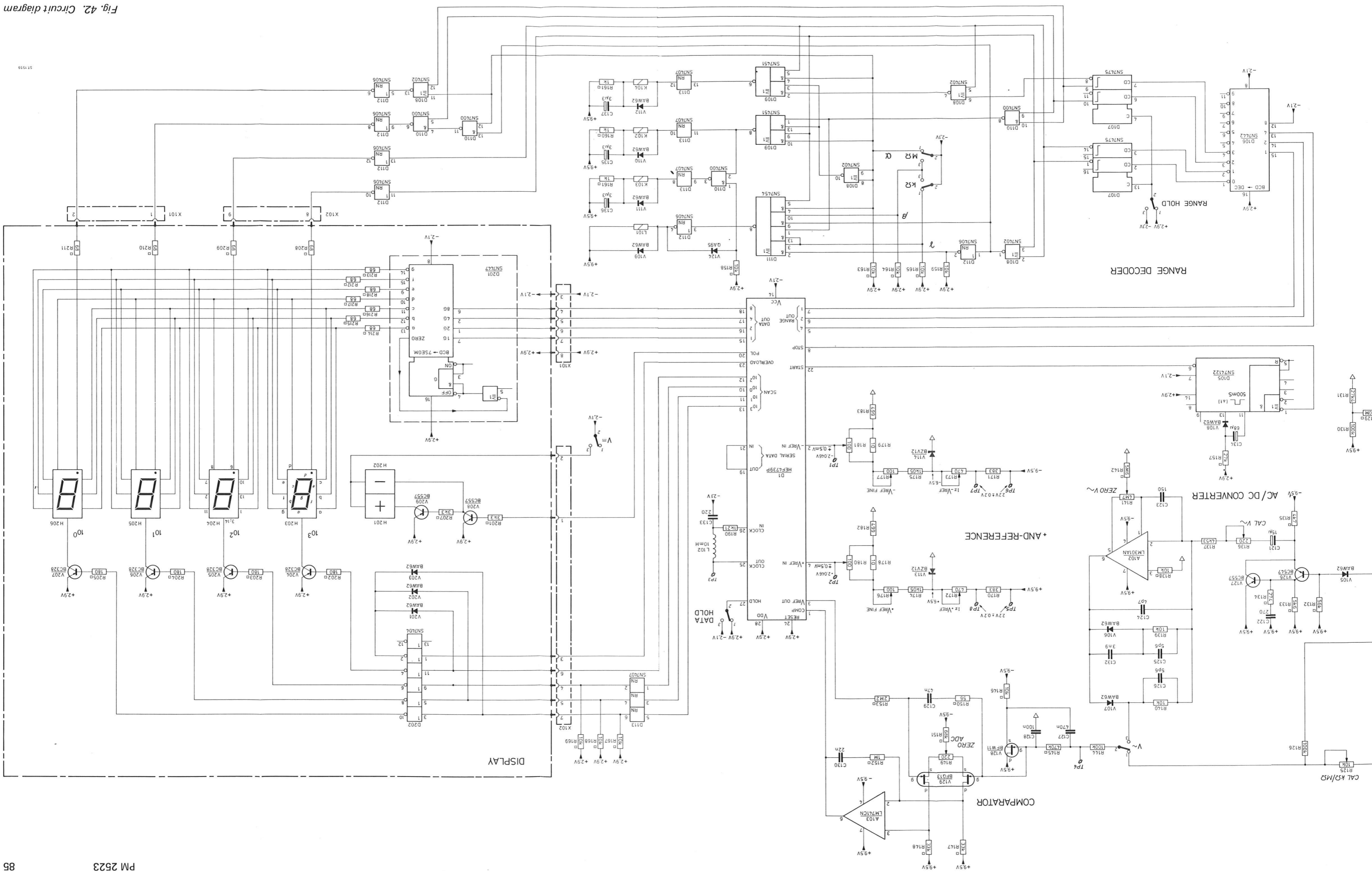

Fig. 42. Circuit diagram

51-1555



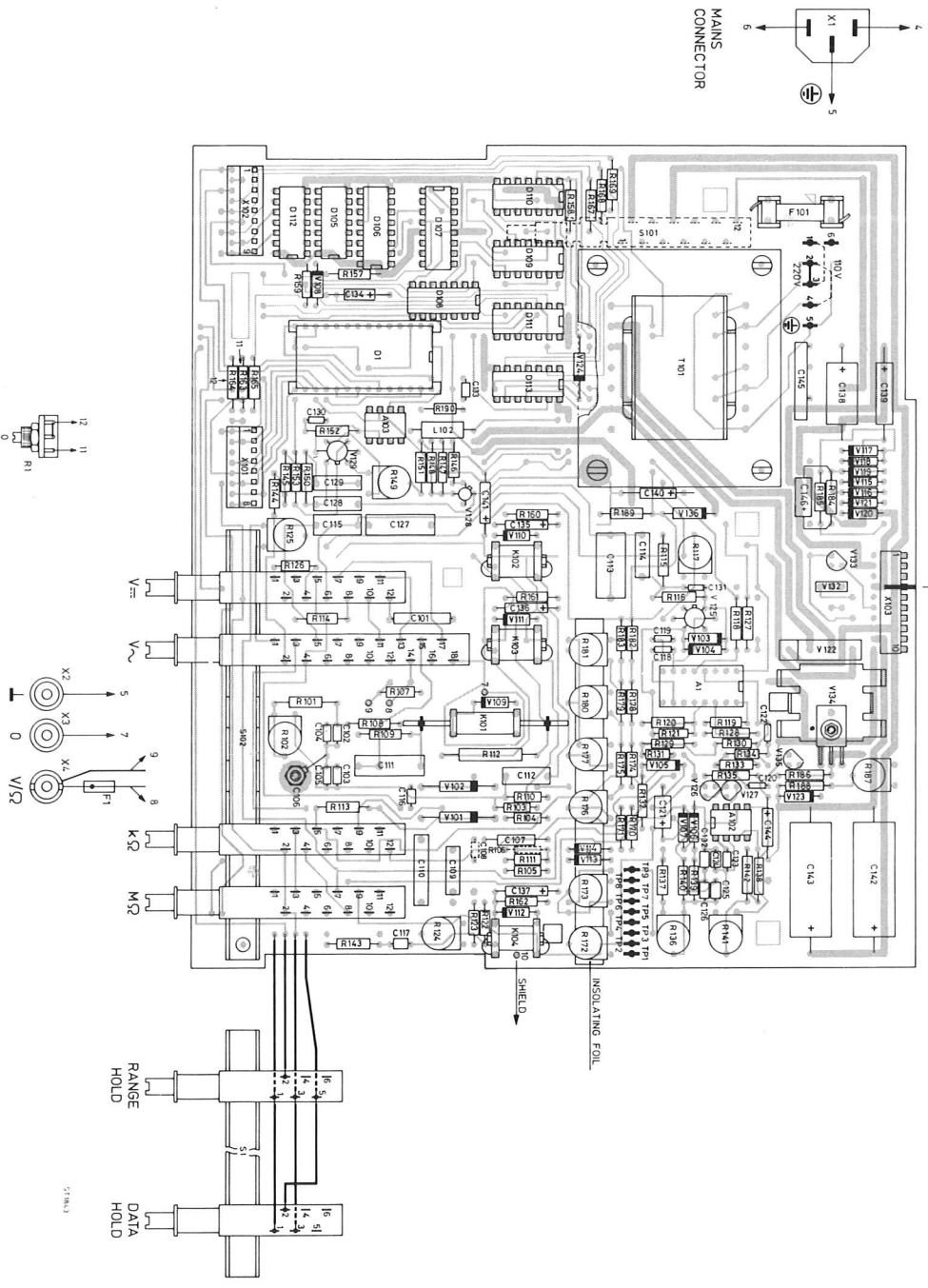

Fig. 38. P.c.b. U1 (component side)

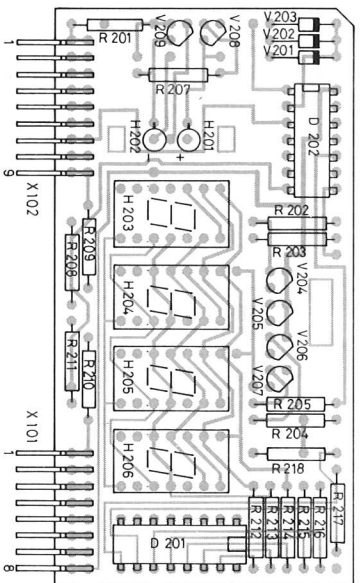

Fig. 40. P.c.b. U2 (component side)

ST 1557

57 1643

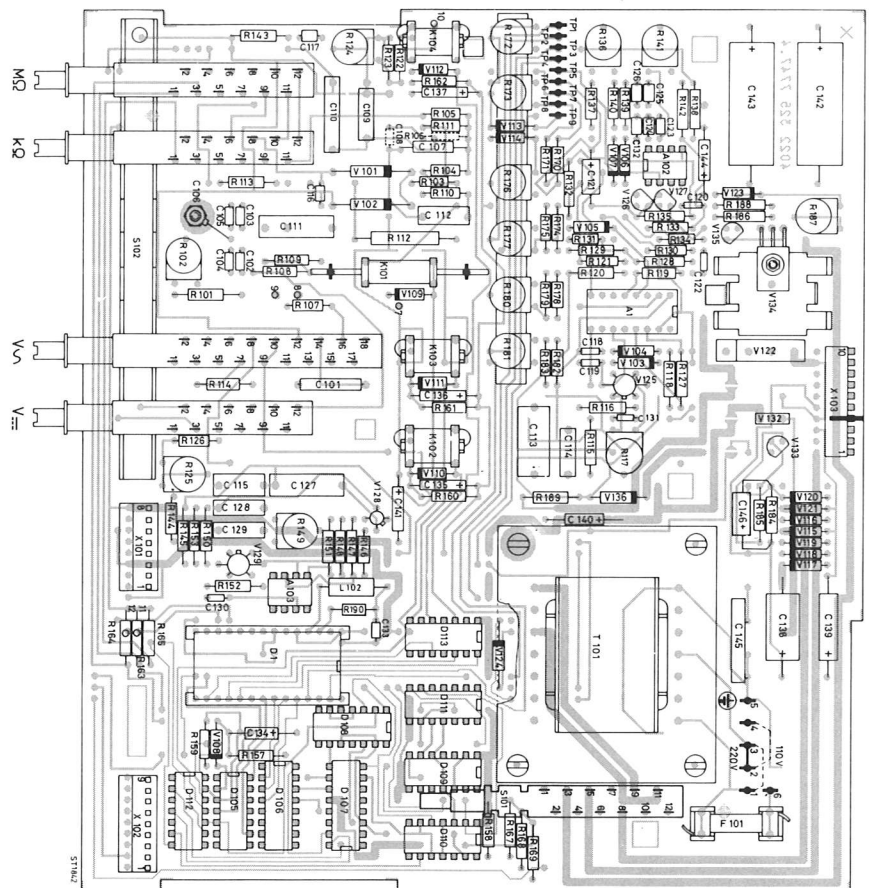

Fig. 39. P.c.b. U1 (conductor side)

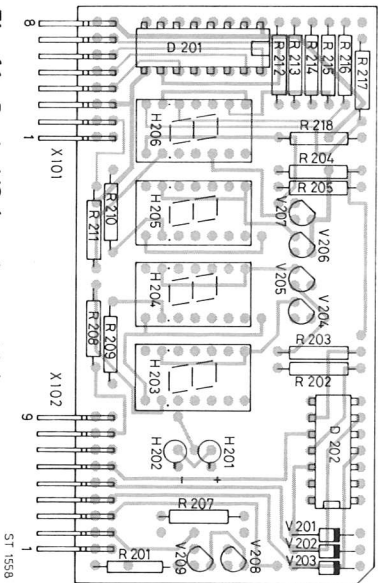

Fig. 41. P.c.b. U2 (conductor side)